

# Hub City HubFlex® Coupling



HubFlex® Features and Advantages . . . . .	Q-2
Green Technology and Sustainability. . . . .	Q-3
Coupling Ordering Nomenclature . . . . .	Q-4
Inserts . . . . .	Q-5
Covers . . . . .	Q-6
Coupling Selection . . . . .	Q-7
Dimensions/Ratings. . . . .	Q-8-9
Bore Sizes and Tolerances . . . . .	Q-10
Torque Ratings . . . . .	Q-11-12
Misalignment Tolerances . . . . .	Q-13
Banded Inserts . . . . .	Q-13
Spacer Hubs and Couplings . . . . .	Q-14-18
Service Factors . . . . .	Q-19-21
Compatibility Chart. . . . .	Q-22
Safety Guidelines. . . . .	Q-23
Quick Selection Guide . . . . .	Q-24

DOWNLOAD AVAILABLE CAD MODELS AT: [WWW.HUBCITYINC.COM](http://WWW.HUBCITYINC.COM)

**Certified prints are available upon request**

EMAIL: [hubsales@regalbeloit.com](mailto:hubsales@regalbeloit.com) • [www.hubcityinc.com](http://www.hubcityinc.com)



# Hub City HubFlex® Coupling

## Introduction

The HubFlex® Coupling made in the USA, is one of the easiest and least expensive couplings to install, maintain, and repair! A complete coupling consists of 2 hubs, available in carbon or stainless steel, a urethane split insert (choose from 5 types), and a cover – either a slide over cover held in by a snap ring or a horizontally split cover for extreme torque applications.

Once you have correctly selected and properly installed a HubFlex® coupling, the split insert is all you should have to replace. Replacement of the insert is easy and your equipment can be back up and running in minutes! Once the hubs are installed, they never need to be moved again. Remove only the cover, replace the insert, re-install the cover, and you are ready to GO!

### The HubFlex® advantages:

- Fast and **EASY** insert replacement!
  - Low maintenance!
  - No lubrication required!
- Fast and **easy** insert replacement.
  - Low maintenance.
  - Minimal downtime.
  - No lubrication required.
  - Urethane inserts available from **Standard Duty** to **eXtreme Duty**, **High Temperature**, and **Food Grade**.
  - Can be installed vertically.
  - Compact.
- The teeth on the hubs do not touch or overlap thus if the insert fails, you do not have metal to metal contact that will potentially destroy the hubs.
  - Reversing applications.
  - No realignment required after insert replacement.
  - We use PM material – a **Green Technology**.



DOWNLOAD AVAILABLE CAD MODELS AT: [WWW.HUBCITYINC.COM](http://WWW.HUBCITYINC.COM)

**Certified prints are available upon request**

**CALL: (605) 225-0360 • FAX: (605) 225-0567**

# Hub City HubFlex® Coupling

## Green Technology & Sustainability

### A RECOGNIZED GREEN TECHNOLOGY

HubFlex® Couplings are made from Powdered Metal (PM), which uses less energy in the manufacturing process, using “green” technology.



### The Sustainability Role of Powder Metallurgy

For many years, powder metallurgy has been delivering sustainable value as an industry. The following explanation compares and contrasts PM’s sustainable value with other metal forming processes.

Addressing manufacturing processes, PM’s sustainable value is primarily derived from its net-shape capabilities and its very high material-utilization factor, which minimizes all energy inputs. In general, any metal component can be manufactured by any of several manufacturing technologies. A simple gear can be produced by machining a cylindrical piece of solid bar stock, forging a steel blank in forging dies, in some cases stamping it from sheet or roll stock, possibly casting it and machining features, or in the case of PM compacting powder in tooling dies that result in the product’s final shape. The trick to evaluating the sustainability of a product’s manufacture will be found in comparing the process steps, resources, and economic costs that go into the manufacture of that product.

The net-shape capability of PM is the primary advantage in the process. When evaluating a component, such as a gear shape, you can quickly realize that there is no waste in the shaping of the component. Production of the gear by chip-generating machining would result in perhaps 40% of the material being machined away and discarded. While the machining waste can be recycled, it is extraneous to the final component and is a net loss to the material and energy eco-efficiency of the final component.

It is estimated that 85% of all PM powders are produced from recycled material. Most metals can be repetitively recycled in collectable quantities. The predominant metal powder used, iron/steel, nearly a half million tons per year, is nearly always produced via atomization of electrically melted steel scrap. Particle-size distribution in a given sample or lot of powder is controlled by sieving operations, and if the particle size needs to be adjusted, the powders can be milled to avoid waste of oversized particles. PM fabrication facilities generally realize operational-scrap losses of 3 percent or less.

The net-shape nature of PM similarly influences the energy demand per component. All manufacturing processes require the use of thermal, chemical, or mechanical energy to achieve product form. Some processes require several heating and re-heating steps to achieve final form. The only time metal for powders is melted is in the atomization step; all other thermal operations are undertaken below melting temperature, conserving energy while achieving the final shape and developing the necessary material properties/mechanical performance. In addition, there is little if any finishing to final product specifications necessary, further conserving the energy necessary to achieve final product characteristics.

### Sustainable Employment



U.S. manufacturing contributes more economic activity than any other sector of the economy, with each dollar of manufactured goods generating \$1.37 of additional economic activity. According to statistics developed by the Manufacturing Institute, manufacturing jobs pay 9% more than all employees in the U.S. economy. PM manufacturing contributes significantly to local economies. In North Central Pennsylvania there is a high concentration of PM manufacturers, which constitute a significant element of the local economy in this rural area. Many companies and their employees are active in supporting community organizations.

DOWNLOAD AVAILABLE CAD MODELS AT: [WWW.HUBCITYINC.COM](http://WWW.HUBCITYINC.COM)

**Certified prints are available upon request**

EMAIL: [hubsales@regalbeloit.com](mailto:hubsales@regalbeloit.com) • [www.hubcityinc.com](http://www.hubcityinc.com)



# Hub City HubFlex® Coupling

## Coupling Ordering Nomenclature

### Hubs (2 required)

Information required: Coupling Size, Bore Sizes (driver and driven), and material (carbon steel or stainless steel)

Example: Coupling Size: HF20  
Bore Size: 5/8" Carbon Steel

HF20 CS 010 H

<b>Coupling Series</b> HF10 HF20 HF30 HF40 HF50 HF60 HF70	<b>Consult Factory</b> HF80 HF90 HF100 HF110 HF120	<b>Material</b> CS = Carbon Steel SS = Stainless Steel  Sizes HF50 thru HF70 are ductile iron	<b>Size*</b> PB = Pilot Bore 008 = 1/2" 010 = 5/8" 012 = 3/4" 014 = 7/8" 100 = 1" 102 = 1-1/8" 103 = 1-3/16" 104 = 1-1/4" 106 = 1-3/8" 107 = 1-7/16" 108 = 1-1/2" 110 = 1-5/8" 112 = 1-3/4" 114 = 1-7/8" 115 = 1-15/16" 200 = 2" 202 = 2-1/8" 203 = 2-3/16" 204 = 2-1/4" 206 = 2-3/8" 207 = 2-7/16" 208 = 2-1/2" 210 = 2-5/8" 212 = 2-3/4" 214 = 2-7/8" 215 = 2-15/16" 300 = 3"	<b>SPACER HUBS ONLY:</b> Spacer Hub Length: (F or F1 dimension) 12 = 1.16 14 = 1.37 17 = 1.65-1.67 18 = 1.75-1.77 19 = 1.90-1.92 21 = 2.08-2.10 24 = 2.39-2.42 29 = 2.92	<b>Description</b> H = Hub S = Spacer SH = Spacer hub
--	---	---	---	---	--

HF50 thru HF70 (Ductile Iron)      \*Metric, Shrink Fit, Spline Bores available on request.



### Insert

Information required: Coupling Size, Insert Type: Standard (Orange), Medium (Green), Extreme (Black), Hi-Temp (Grey), or Food Grade (White)

Example: Coupling Size: HF20  
Insert type: Standard (Orange)

HF20 SD -INS

<b>Coupling Series</b> HF10 HF20 HF30 HF40 HF50 HF60 HF70	<b>Consult Factory</b> HF80 HF90 HF100 HF110 HF120	<b>Material</b> SD = Standard Duty (Orange) MD = Medium (Green) XD = Extreme (Black) HT = Hi-Temp (Grey) FG = Food Grade (White) SB = Banded	<b>Description</b> -INS = Insert
--	---	--	-------------------------------------



### Cover

Information required: Coupling Size, Standard (specify Carbon Steel or Stainless Steel), or Extreme Duty (Horizontal Split)

Example: Coupling Size: HF20  
Cover: Standard - Carbon Steel

HF20 SD -CVR

<b>Coupling Series</b> HF10 HF20 HF30 HF40 HF50 HF60 HF70	<b>Consult Factory</b> HF80 HF90 HF100 HF110 HF120	<b>Type</b> SD = Standard Duty (Carbon Steel) SS = Stainless Steel (Std Duty) XH = Extreme Duty (Horz Split)  Spacer Coupling Standard duty covers only: CM = Carbon Steel Modified for Spacer duty SM = Stainless Steel Modified for Spacer Duty	<b>Description</b> -CVR = Cover	Standard covers available on sizes HF10 thru HF40
--	---	--	------------------------------------	---



XH covers available from sizes HF20 thru HF70

DOWNLOAD AVAILABLE CAD MODELS AT: [WWW.HUBCITYINC.COM](http://WWW.HUBCITYINC.COM)

Certified prints are available upon request

CALL: (605) 225-0360 • FAX: (605) 225-0567

# Hub City HubFlex® Coupling

## Inserts

HubFlex® Couplings utilize urethane inserts which are resistant to oils, corrosion, most chemicals, and have excellent wear properties. Inserts are available in five materials for various applications.



### HubFlex® Orange INSERT (Standard)

- Operational temperature range of -60°F to 200°F (-50°C to 93°C).
- The regular Orange insert is made from a moderately soft urethane compound.
- Applications – vibration dampening, cushioning of shock loads, reversing, or quick starting and stopping of high inertial loads.



### HubFlex® GREEN INSERT (Medium Torque)

- Operational temperature range of -60°F to 200°F (-50°C to 93°C).
- The green insert has a higher durometer urethane resulting in a more rigid insert designed for higher torque applications than the regular insert.
- Applications – moderate to high torque. Excellent replacements for gear or grid style couplings.



### HubFlex® BLACK INSERT (Extreme - Highest Torque)

- Operational temperature range of -60°F to 200°F (-50°C to 93°C).
- The black insert provides our highest torque ratings.
- Applications – excellent replacements for gear and grid style couplings.



### HubFlex® GREY INSERT (High Temperature)

- Operational temperature range up to 300°F (150°C)
- The grey insert is made for applications where heat is a concern.
- Applications – same capabilities as our green insert.
- Consult Factory for Operating temperatures above 300°F.



### HubFlex® WHITE INSERT (Food Grade)

- Operational temperature range of -60°F to 200°F (-50°C to 93°C).
- The food grade white insert is FDA approved for use with both wet and dry foods.
- Applications – similar capabilities as the Orange insert.
- HF10 thru HF40 stock, HF50 and above available upon request.

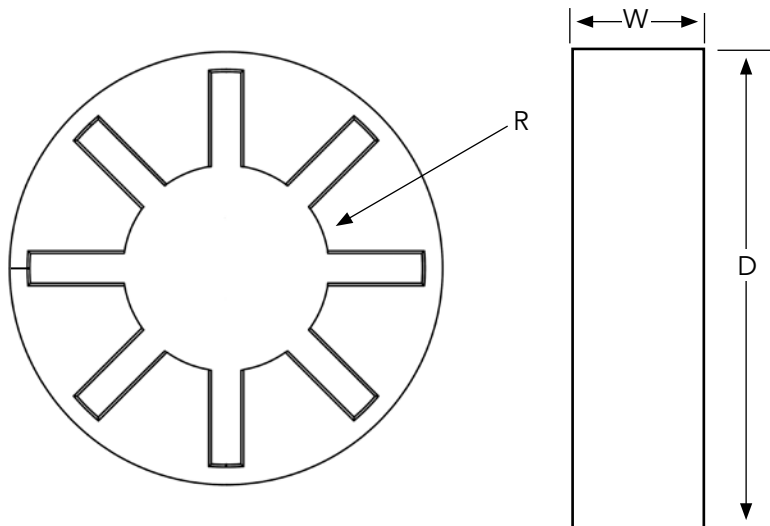

HubFlex® Insert Dimensions (in.)

Coupling Series	R	D	W	Wt. (lbs)
HF10	1.23	2.23	0.63	0.05
HF20	1.66	2.86	0.85	0.10
HF30	2.16	3.80	1.23	0.30
HF40	2.41	5.05	1.64	0.80
HF50	3.05	6.44	2.02	1.45
HF60	3.90	7.37	2.35	2
HF70	4.13	8.20	2.32	3
Additional Sizes Available On Request - Consult Factory				
HF80	4.34	9.98	2.63	5
HF90	6.19	11.30	2.96	6
HF100	7.60	13.61	3.24	9
HF110	9.15	15.93	3.67	13
HF120	11.25	19.04	5.43	31

DOWNLOAD AVAILABLE CAD MODELS AT: [WWW.HUBCITYINC.COM](http://WWW.HUBCITYINC.COM)

**Certified prints are available upon request**

EMAIL: [hubsales@regalbeloit.com](mailto:hubsales@regalbeloit.com) • [www.hubcityinc.com](http://www.hubcityinc.com)



# Hub City HubFlex® Coupling Covers

## HubFlex® Standard Cover

Designed for applications where low torque and/ or high speed is present.

HubFlex® Standard Cover  
Dimensions (in.)

COVER PART # (XX=Material)	MAXIMUM RPM*	D	W	WEIGHT (lbs.)
HF10XX-CVR	4000	2.49	0.95	.3
HF20XX-CVR	4000	3.16	1.35	.78
HF30XX-CVR	4000	4.21	1.95	2.1
HF40XX-CVR	4000	5.48	2.38	3.3
Additional Sizes Available Upon Request - Consult Factory				
HF50XX-CVR	4000	7.00	2.96	10.3
HF60XX-CVR	4000	8.00	3.27	11.2
HF70XX-CVR	3800	8.88	3.50	17.9
HF80XX-CVR	3400	10.77	4.05	18

\* For applications over 4000 RPM, consult factory

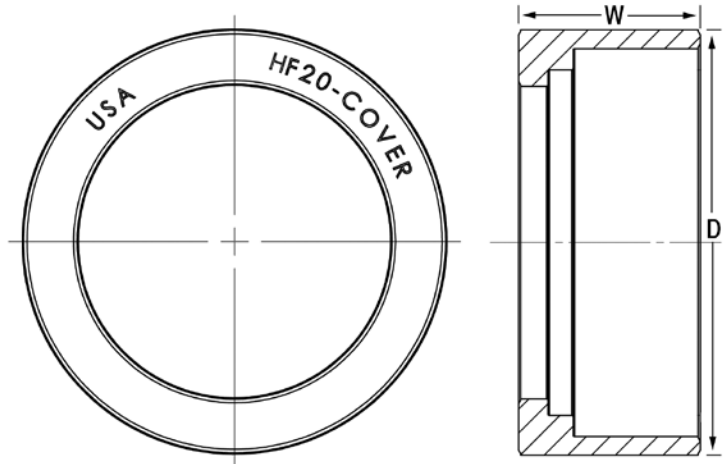

## HubFlex® Extreme Duty Cover

Designed for all applications including high or low torque and speed ratings while eliminating axial loading.

HubFlex® Extreme  
Duty Cover Dimensions (in.)

COVER PART #	MAXIMUM RPM*	W	D	BOLT SIZE	WEIGHT (lbs.)
HF20XH-CVR	4000	1.93	3.99	(4) 3/8 nc x 1-1/4	1.1
HF30XH-CVR	4000	2.61	5.34	(4) 1/2 nc x 2	2.5
HF40XH-CVR	4000	3.02	7.28	(4) 1/2 nc x 1-3/4	5.7
HF50XH-CVR	4000	5.96	7.76	(4) 1/2 nc x 2-1/4	10.3
HF60XH-CVR	4000	6.17	8.52	(4) 5/8 nc x 2-1/2	11.2
HF70XH-CVR	3800	6.54	10.29	(4) 3/4 nc x 3-1/2	17.9
Additional Sizes Available Upon Request - Consult Factory					
HF80XH-CVR	3000	7.93	12.05	(4) 3/4 nc x 3-1/2	18

\* For applications over 4000 RPM, consult factory  
Stainless steel hardware provided with all Extreme Duty covers

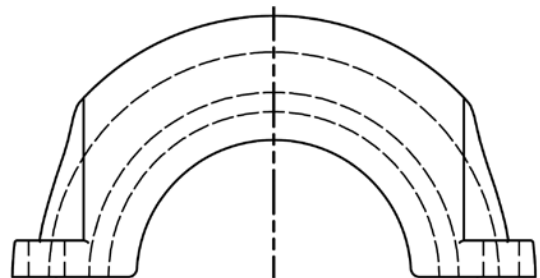
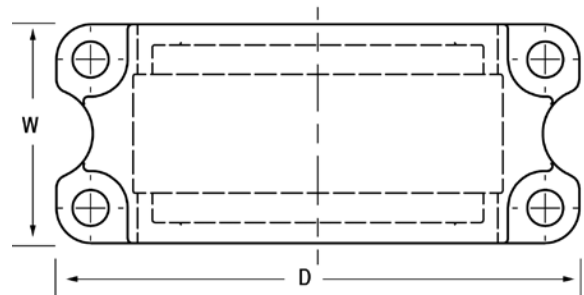

DOWNLOAD AVAILABLE CAD MODELS AT: [WWW.HUBCITYINC.COM](http://WWW.HUBCITYINC.COM)

**Certified prints are available upon request**

**CALL: (605) 225-0360 • FAX: (605) 225-0567**

# Hub City HubFlex® Coupling

## Coupling Selection

### HubFlex® Coupling Selection

Information required before a coupling can be selected:

- HP and RPM or torque of driver
- Shaft sizes of driver and driven equipment
- Corresponding keyways
- Application description to determine service factor
- Environmental conditions

Step 1: Determine the Nominal Torque (T) of your application:

$$\text{in/lbs} = T = \frac{(63025 \times \text{HP})}{\text{RPM}}$$

HP = Drive Horsepower

RPM = Drive Shaft Revolutions Per Minute

Step 2: Refer to pages 15-17 to determine Application Service Factor

Step 3: Calculate the Design Torque of your application.

Design Torque = Nominal Torque (T) x Application Service Factor

Example:

Driver: 5HP, 1800RPM electric motor

Driven: belt conveyor (refer to pages 15-17)

$$\text{in/lbs} = T = \frac{(63025 \times 5\text{HP})}{1800}$$

Nominal Torque (T) = 175 in/lbs

Design Torque = 175 (Nominal Torque) x 1.75 (Application Service Factor from pages 15-17)

Design Torque = 306.25 in/lbs Torque

Step 4: Refer to page 8 to select correct coupling size - ie. HF10

Step 5: Confirm that the shaft size of the driver and driven shafts are equal to or less than the maximum bore size (refer to coupling dimensional pages)

Step 6: Confirm environmental conditions to determine correct cover, hubs, and insert material (stainless steel or carbon steel hubs and cover, food grade, high temp or standard insert)

\* For reversing applications with high inertia loads, please Consult Factory.

DOWNLOAD AVAILABLE CAD MODELS AT: [WWW.HUBCITYINC.COM](http://WWW.HUBCITYINC.COM)

**Certified prints are available upon request**

EMAIL: [hubsales@regalbeloit.com](mailto:hubsales@regalbeloit.com) • [www.hubcityinc.com](http://www.hubcityinc.com)





# Hub City HubFlex® Coupling

## Dimensions/Ratings

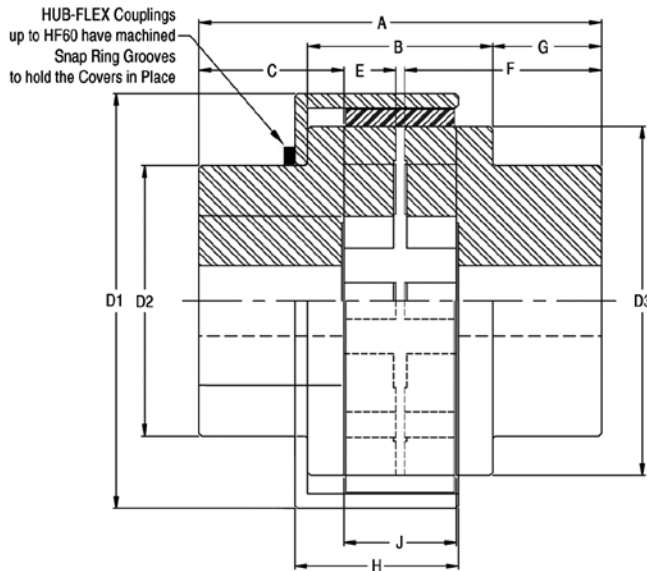

‡Note: Sizes HF50 thru HF70 Standard Cover are available upon request.

## HubFlex® Standard Coupling Dimensions (in.)

COUPLING SERIES	PILOT BORE DIAMETER	MAXIMUM BORE SIZE****	MAXIMUM RPM*	MAXIMUM TORQUE (in-lbs)***	A	B	D1	D2	D3	C	E <sub>MIN</sub>	E <sub>MAX</sub>	F	G	H	J	WT** (lbs)
HF10	1/2	1-1/4	4000	792	2.80	1.03	2.49	2.00	2.07	1.08	0.062	0.092	1.37	0.88	0.95	0.66	2.5
HF20	1/2	1-5/8	4000	1965	3.54	1.28	3.16	2.31	2.55	1.34	0.036	0.110	1.75	1.14	1.35	0.88	4.2
HF30	3/4	2-1/8	4000	6183	4.86	2.00	4.21	3.19	3.37	1.81	0.080	0.205	2.39	1.42	1.95	1.21	10.4
HF40	7/8	2-3/8	4000	13680	5.96	2.42	5.48	3.52	4.49	2.16	0.035	0.208	2.96	1.78	2.38	1.66	16.2
HF50‡	1	3	4000	27468	7.07	3.48	7.00	4.25	5.92	2.46	0.140	0.290	3.40	1.76	2.96	2.19	37
HF60‡	1	3-7/8	4000	46510	7.69	3.67	8.00	5.50	6.75	2.67	0.188	0.208	3.75	2.00	3.27	2.45	57
HF70‡	1-1/2	4-1/8	3800	60430	8.51	3.96	8.88	5.79	7.48	3.10	0.100	0.230	4.21	2.33	3.50	2.49	71
Additional Sizes Available On Request - Consult Factory																	
HF80	1-7/8	4-1/2	3400	114227	10.13	4.67	10.77	7.00	9.25	3.75	0.125	0.250	5.00	2.75	4.05	2.75	126

\* For applications over 4000 RPM, consult factory

\*\* All weights shown are approximate for a complete standard coupling assembly.

\*\*\* Maximum torque values (in-lbs) are based on use with green insert. Refer to page 12 for complete torque ratings.

\*\*\*\* Maximum bore size has reduced keyway on sizes HF20, HF30 and HF40.

Reduced keyways in max bore hubs measure as follows: HF20X1-5/8" - 3/8" x 3/32" keyway, HF30X2-1/8" - 1/2" x 1/8" keyway, HF40X2-3/8" - 5/8" x 5/32" keyway

## HubFlex® Insert Maximum Torque Ratings (in-lbs)

COUPLING SERIES	ORANGE	GREEN	BLACK	GREY	WHITE
HF10	365	792	-	792	365
HF20	1003	1965	-	1965	1003
HF30	3279	6183	-	6183	3279
HF40	6903	13680	-	13680	6903
HF50	13852	27468	-	27468	13852
HF60	24282	46510	-	46510	24282
HF70	30438	60430	-	60430	30438
Estimated Torque Ratings for Additional Sizes Available On Request - Consult Factory					
HF80	59430	114227	-	114227	59430

It is not recommended to use the Black insert with the Standard Cover. In high torque applications we recommend the use of the Extreme Duty Cover.

DOWNLOAD AVAILABLE CAD MODELS AT: [WWW.HUBCITYINC.COM](http://WWW.HUBCITYINC.COM)

Certified prints are available upon request

CALL: (605) 225-0360 • FAX: (605) 225-0567



# Hub City HubFlex® Coupling

## Dimensions/Ratings

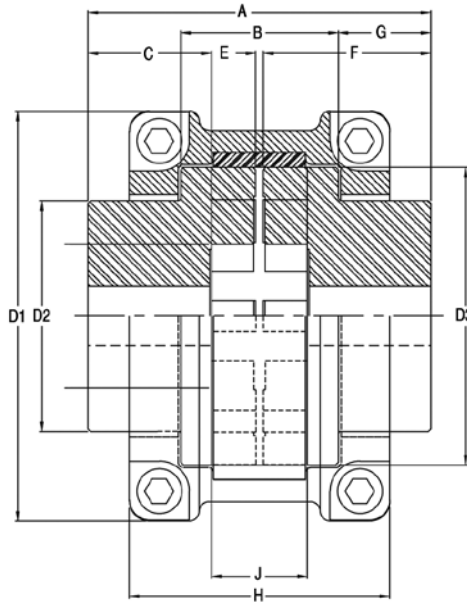

### HubFlex® Extreme Duty Coupling Dimensions (in.)

COUPLING SERIES	PILOT BORE DIAMETER	MAXIMUM BORE SIZE ****	MAXIMUM RPM*	MAXIMUM TORQUE (in-lbs)***	A	B	D1	D2	D3	C	E <sub>MIN</sub>	E <sub>MAX</sub>	F	G	H	J	WT** (lbs)
HF20	1/2	1-5/8	4000	3789	3.54	1.28	3.99	2.31	2.55	1.34	0.036	.220	1.75	1.14	1.93	0.88	4.5
HF30	3/4	2-1/8	4000	11914	4.86	2.00	5.34	3.19	3.37	1.81	0.080	0.160	2.39	1.42	2.61	1.21	10.7
HF40	7/8	2-3/8	4000	25870	5.96	2.42	7.28	3.52	4.49	2.16	0.035	0.160	2.96	1.78	3.02	1.66	18.8
HF50	1	3	4000	52408	7.07	3.48	7.76	4.25	5.92	2.46	0.140	0.370	3.40	1.76	5.96	2.19	40.2
HF60	1	3-7/8	3600	87110	7.69	3.67	8.52	5.50	6.75	2.67	0.188	0.368	3.75	2.00	6.17	2.45	59.0
HF70	1-1/2	4-1/8	3600	116432	8.51	3.96	10.29	5.79	7.48	3.10	0.100	0.318	4.21	2.33	6.54	2.49	82.1
Available on Request - Consult Factory																	
HF80	1-7/8	4-1/2	3400	214821	10.13	4.67	12.02	7.00	9.25	3.75	0.125	0.375	5.00	2.75	7.92	2.75	138.0

\* For applications over 4000 RPM, consult factory

\*\* All weights shown are approximate for a complete standard coupling assembly.

\*\*\* Maximum torque values (in-lbs) are based on use with black insert. Refer to page 13 for complete torque ratings.

\*\*\*\* Maximum bore size has reduced keyway on sizes HF20, HF30 and HF40.

Reduced keyways in max bore hubs measure as follows: HF20X1-5/8" - 3/8" x 3/32" keyway, HF30X2-1/8" - 1/2" x 1/8" keyway, HF40X2-3/8" - 5/8" x 5/32" keyway

### HubFlex® Insert Maximum Torque Ratings (in-lbs)

COUPLING SERIES	ORANGE	GREEN	BLACK	GREY	WHITE
HF20	1254	2457	3789	2457	1254
HF30	4099	7730	11914	7730	4099
HF40	8630	17099	25870	17099	8630
HF50	17315	34336	52408	34336	17315
HF60	30353	58137	87110	58137	30353
HF70	38048	75538	116432	75538	38048
Estimated Torque Ratings for Additional Sizes Available On Request - Consult Factory					
HF80	73537	141340	214821	141340	73537

DOWNLOAD AVAILABLE CAD MODELS AT: [WWW.HUBCITYINC.COM](http://WWW.HUBCITYINC.COM)

**Certified prints are available upon request**

EMAIL: [hubsales@regalbeloit.com](mailto:hubsales@regalbeloit.com) • [www.hubcityinc.com](http://www.hubcityinc.com)



# Hub City HubFlex® Coupling

## Bore - Keyway Sizes and Tolerances

### HubFlex® Standard Bore Sizes

COUPLING SIZE	PB	1/2"	5/8"	3/4"	7/8"	1"	1-1/8"	1-3/16"	1-1/4"	1-3/8"	1-7/16"	1-1/2"	1-5/8"	1-3/4"	1-7/8"	1-15/16"
HF10	X	X	X	X	X	X	X	X	X							
HF20	X		X	X	X	X	X	X	X	X	X	X	X			
HF30	X				X	X	X	X	X	X	X	X	X	X	X	X
HF40	X				X	X	X		X	X	X	X	X	X	X	X
HF50	X											X	X	X	X	X
HF60	X															
HF70	X															
Available on Request - Consult Factory																
HF80	X															

### HubFlex® Standard Bore Sizes (cont'd.)

COUPLING SIZE	2"	2-1/8"	2-3/16"	2-1/4"	2-3/8"	2-7/16"	2-1/2"	2-5/8"	2-3/4"	2-7/8"	2-15/16"	3"
HF10												
HF20												
HF30	X	X										
HF40	X	X	X	X	X							
HF50	X	X		X	X	X	X	X	X	X	X	X
HF60												
HF70												

### HubFlex® Bore Tolerances and Keyway Sizes

SHAFT DIAMETER (NOMINAL)	KEYWAY SIZE (NOMINAL)		BORE TOLERANCES				SET SCREW SIZE
	WIDTH	DEPTH	CLEARANCE FIT **		INTERFERENCE FIT **		
1/2" - 9/16"	1/8"	1/16"	+0.0015	-0.0000	-0.0005	-0.0010	5/16"
5/8" - 7/8"	3/16"	3/32"	+0.0015	-0.0000	-0.0005	-0.0010	5/16"
15/16" - 1-1/4"	1/4"	1/8"	+0.0015	-0.0000	-0.0005	-0.0010	5/16"
1-5/16" - 1-3/8"	5/16"	5/32"	+0.0015	-0.0000	-0.0005	-0.0010	5/16"
1-7/16" - 1-3/4"	3/8"	3/16"	+0.0015	-0.0000	-0.0005	-0.0015	5/16"
1-13/16" - 2-1/4"	1/2"	1/4"	+0.0025	-0.0000	-0.0005	-0.0015	3/8"
2-5/16" - 2-3/4"	5/8"	5/16"	+0.0025	-0.0000	-0.0010	-0.0020	1/2"
2-13/16" - 3-1/4"	3/4"	3/8"	+0.0025	-0.0000	-0.0010	-0.0020	5/8"
3-5/16" - 3-3/4"	7/8"	7/16"	+0.0025	-0.0000	-0.0015	-0.0025	5/8"
3-13/16" - 4-1/2"	1"	1/2"	+0.0025	-0.0000	-0.0025	-0.0035	5/8"

\*\* For Class 1 Fit

Reduced keyways in max bore hubs measure as follows: HF20X1-5/8" - 3/8" x 3/32" keyway, HF30X2-1/8" - 1/2" x 1/8" keyway, HF40X2-3/8" - 5/8" x 5/32" keyway

DOWNLOAD AVAILABLE CAD MODELS AT: [WWW.HUBCITYINC.COM](http://WWW.HUBCITYINC.COM)

**Certified prints are available upon request**

**CALL: (605) 225-0360 • FAX: (605) 225-0567**

# Hub City HubFlex® Coupling Torque Ratings

## Torque Ratings for HubFlex® Couplings with Standard Cover

COUPLING SERIES	INSERT PART #	INSERT COLOR	CONTINUOUS TORQUE (IN-LBS)	HP RATINGS @ VARIOUS RPM (SERVICE FACTOR = 1)							
				100	300	600	900	1200	1800	2400	3600
HF10	HF10SD-INS	Orange	365	.58	1.74	3.48	5.22	6.96	10.44	13.92	20.88
	HF10MD-INS	Green	792	1.26	3.78	7.56	11.34	15.12	22.68	30.24	45.36
	HF10FG-INS	White	365	.58	1.74	3.48	5.22	6.96	10.44	13.92	20.88
HF20	HF20SD-INS	Orange	1003	1.59	4.77	9.54	14.31	19.08	28.62	38.16	57.24
	HF20MD-INS	Green	1965	3.12	9.36	18.72	28.08	37.44	56.16	74.88	112.32
	HF20HT-INS	Grey	1965	3.12	9.36	18.72	28.08	37.44	56.16	74.88	112.32
	HF20FG-INS	White	1003	1.59	4.77	9.54	14.31	19.08	28.62	38.16	57.24
HF30	HF30SD-INS	Orange	3279	5.20	15.60	31.20	46.80	62.40	93.60	124.80	187.20
	HF30MD-INS	Green	6183	9.81	29.43	58.86	88.29	117.72	176.58	235.44	353.16
	HF30HT-INS	Grey	6183	9.81	29.43	58.86	88.29	117.72	176.58	235.44	353.16
	HF30FG-INS	White	3279	5.20	15.60	31.20	46.80	62.40	93.60	124.80	187.20
HF40	HF40SD-INS	Orange	6903	10.95	32.85	65.70	98.55	131.40	197.10	262.80	394.20
	HF40MD-INS	Green	13680	21.71	65.13	130.26	195.39	260.52	390.78	521.04	781.56
	HF40HT-INS	Grey	13680	21.71	65.13	130.26	195.39	260.52	390.78	521.04	781.56
	HF40FG-INS	White	6903	10.95	32.85	65.70	98.55	131.40	197.10	262.80	394.20
HF50	HF50SD-INS	Orange	13852	21.98	65.94	131.88	197.82	263.76	395.64	527.52	791.28
	HF50MD-INS	Green	27468	43.58	130.74	261.48	392.22	522.96	784.44	1045.92	1568.88
	HF50HT-INS	Grey	27468	43.58	130.74	261.48	392.22	522.96	784.44	1045.92	1568.88
	HF50FG-INS	White	13852	21.98	65.94	131.88	197.82	263.76	395.64	527.52	791.28
HF60	HF60SD-INS	Orange	24282	38.53	115.59	231.88	346.77	462.36	693.54	924.72	1387.08
	HF60MD-INS	Green	46510	73.80	221.40	442.80	664.20	885.60	1328.40	1771.20	2656.80
	HF60HT-INS	Grey	46510	73.80	221.40	442.80	664.20	885.60	1328.40	1771.20	2656.80
	HF60FG-INS	White	24282	38.53	115.59	231.88	346.77	462.36	693.54	924.72	1387.08
HF70	HF70SD-INS	Orange	30438	48.30	144.90	289.80	434.70	579.60	869.40	1159.20	1738.80
	HF70MD-INS	Green	60430	95.88	287.64	575.28	862.92	1150.56	1725.84	2301.12	3451.68
	HF70HT-INS	Grey	60430	95.88	287.64	575.28	862.92	1150.56	1725.84	2301.12	3451.68
	HF70FG-INS	White	30438	48.30	144.90	289.80	434.70	579.60	869.40	1159.20	1738.80
Estimated Torque Ratings for Additional Sizes Available On Request - Consult Factory											
HF80	HF80SD-INS	Orange	59430	94.30	282.90	565.80	848.70	1131.60	1697.40	2263.20	3394.80
	HF80MD-INS	Green	114227	181.24	543.72	1087.44	1631.17	2174.99	3262.32	4349.76	6524.64
	HF80HT-INS	Grey	114227	181.24	543.72	1087.44	1631.17	2174.99	3262.32	4349.76	6524.64
	HF80FG-INS	White	59430	94.30	282.90	565.80	848.70	1131.60	1697.40	2263.20	3394.80

HubFlex® flexible couplings can sustain momentary peak torque loads in excess of 200% of its maximum torque rating.

Standard duty covers sizes HF50 thru HF70 - Available upon request.

DOWNLOAD AVAILABLE CAD MODELS AT: [WWW.HUBCITYINC.COM](http://WWW.HUBCITYINC.COM)

**Certified prints are available upon request**

EMAIL: [hubsales@regalbeloit.com](mailto:hubsales@regalbeloit.com) • [www.hubcityinc.com](http://www.hubcityinc.com)



# Hub City HubFlex® Coupling

## Torque Ratings

### Torque Ratings for HubFlex® Couplings with Extreme Duty Cover

COUPLING SERIES	INSERT PART #	INSERT COLOR	CONTINUOUS TORQUE (IN-LBS)	HP RATINGS @ VARIOUS RPM (SERVICE FACTOR = 1)							
				100	300	600	900	1200	1800	2400	3600
HF20	HF20SD-INS	Orange	1254	1.99	5.97	11.94	17.91	23.88	35.82	47.76	71.64
	HF20MD-INS	Green	2457	3.90	11.70	23.40	35.10	46.80	70.20	93.60	140.40
	HF20XD-INS	Black	3789	6.01	18.03	36.06	54.09	72.12	108.18	144.24	216.36
	HF20HT-INS	Grey	2457	3.90	11.70	23.40	35.10	46.80	70.20	93.60	140.40
	HF20FG-INS	White	1254	1.99	5.97	11.94	17.91	23.88	35.82	47.76	71.64
HF30	HF30SD-INS	Orange	4099	6.50	19.50	39.00	58.50	78.00	117.00	156.00	234.00
	HF30MD-INS	Green	7730	12.26	36.78	73.56	110.34	147.12	220.68	294.24	441.36
	HF30XD-INS	Black	11914	18.90	56.70	113.40	170.10	226.80	340.20	453.60	680.40
	HF30HT-INS	Grey	7730	12.26	36.78	73.56	110.34	147.12	220.68	294.24	441.36
	HF30FG-INS	White	4099	6.50	19.50	39.00	58.50	78.00	117.00	156.00	234.00
HF40	HF40SD-INS	Orange	8630	13.69	41.07	82.14	123.21	164.28	246.42	328.56	492.84
	HF40MD-INS	Green	17099	27.13	81.39	162.78	244.17	325.56	488.34	651.12	976.68
	HF40XD-INS	Black	25870	41.05	123.15	246.30	369.45	492.60	738.90	985.20	1477.80
	HF40HT-INS	Grey	17099	27.13	81.39	162.78	244.17	325.56	488.34	651.12	976.68
	HF40FG-INS	White	8630	13.69	41.07	82.14	123.21	164.28	246.42	328.56	492.84
HF50	HF50SD-INS	Orange	17315	27.47	82.41	164.82	247.23	392.64	494.46	659.28	988.92
	HF50MD-INS	Green	34336	54.48	163.44	326.88	490.32	653.76	980.64	1307.52	1961.28
	HF50XD-INS	Black	52408	83.15	249.45	498.90	748.35	997.80	1496.70	1995.60	2993.40
	HF50HT-INS	Grey	34336	54.48	163.44	326.88	490.32	653.76	980.64	1307.52	1961.28
	HF50FG-INS	White	17315	27.47	82.41	164.82	247.23	392.64	494.46	659.28	988.92
HF60	HF60SD-INS	Orange	30353	48.16	144.48	288.96	433.44	577.92	866.88	1155.84	1733.76
	HF60MD-INS	Green	58137	92.24	276.72	553.44	830.16	1106.88	1660.32	2213.76	3320.64
	HF60XD-INS	Black	87110	138.21	414.63	829.26	1243.89	1658.52	2487.78	3317.04	4975.56
	HF60HT-INS	Grey	58137	92.24	276.72	553.44	830.16	1106.88	1660.32	2213.76	3320.64
	HF60FG-INS	White	30353	48.16	144.48	288.96	433.44	577.92	866.88	1155.84	1733.76
HF70	HF70SD-INS	Orange	38048	60.37	181.11	362.22	543.33	724.44	1086.66	1448.88	2173.32
	HF70MD-INS	Green	75538	119.85	359.55	719.10	1078.65	1438.20	2157.30	2876.40	4314.60
	HF70XD-INS	Black	116432	184.74	554.22	1108.44	1662.66	2216.88	3325.32	4433.76	6650.64
	HF70HT-INS	Grey	75538	119.85	359.55	719.10	1078.65	1438.20	2157.30	2876.40	4314.60
	HF70FG-INS	White	38048	60.37	181.11	362.22	543.33	724.44	1086.66	1448.88	2173.32
Estimated Torque Ratings for Additional Sizes Available On Request - Consult Factory											
HF80	HF80SD-INS	Orange	73537	116.68	350.04	700.08	1050.12	1400.16	2100.24	2800.32	4200.48
	HF80MD-INS	Green	141340	224.26	672.78	1345.56	2018.34	2691.12	4036.68	5382.24	8073.36
	HF80XD-INS	Black	214821	340.85	1022.55	2045.10	3067.65	4090.20	6135.30	8180.40	12270.60
	HF80HT-INS	Grey	141340	224.26	672.78	1345.56	2018.34	2691.12	4036.68	5382.24	8073.36
	HF80FG-INS	White	73537	116.68	350.04	700.08	1050.12	1400.16	2100.24	2800.32	4200.48

HubFlex® flexible couplings can sustain momentary peak torque loads in excess of 200% of its maximum torque rating.

DOWNLOAD AVAILABLE CAD MODELS AT: [WWW.HUBCITYINC.COM](http://WWW.HUBCITYINC.COM)

**Certified prints are available upon request**

**CALL: (605) 225-0360 • FAX: (605) 225-0567**

# Hub City HubFlex® Coupling Misalignment Tolerances

## HubFlex® Couplings Misalignment Tolerances

COUPLING SERIES	AXIAL MISALIGNMENT TOLERANCE (IN.)	RADIAL MISALIGNMENT TOLERANCE (IN.)	ANGULAR MISALIGNMENT TOLERANCE
HF10	0.078	0.020	2°
HF20	0.116	0.039	2°
HF30	0.116	0.039	2°
HF40	0.116	0.039	2°
HF50	0.156	0.058	2°
HF60	0.175	0.058	1.3°
HF70	0.234	0.058	1.3°
Additional Sizes Available - Consult Factory			
HF80	0.234	0.058	1°
HF90	0.234	0.058	1°
HF100	0.312	0.058	1°
HF110	0.312	0.078	1°
HF120	0.312	0.078	1°

## HubFlex® Special Banded Inserts *\*Patent Pending\**

COUPLING SERIES	MAXIMUM RPM	MAXIMUM HP (AT 900 RPM)	MAXIMUM TORQUE (IN-LBS)	R	D	W	WT. (LBS)
HF10	3600	2	140	1.23	2.49	0.63	0.10
HF20	3600	10	700	1.66	3.16	0.85	0.20
HF30	3600	30	2100	2.16	4.21	1.23	0.40



Banded inserts are manufactured with an outer ring of high strength urethane and are designed for use in spaces where a cover cannot be accessed or spaces where there is not room for a cover. Please note torque limitations.

Ideal applications include coupled style C-face motor flanges.

# Hub City HubFlex® Coupling

## Spacer Coupling Dimensions

### HubFlex® Spacer Coupling Dimensions with Standard Cover

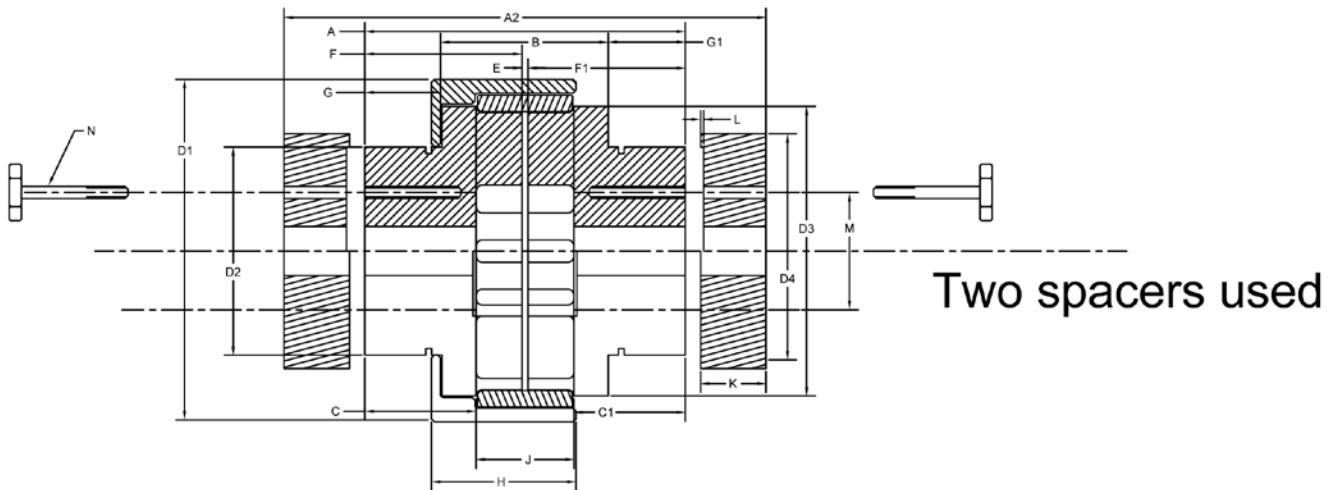
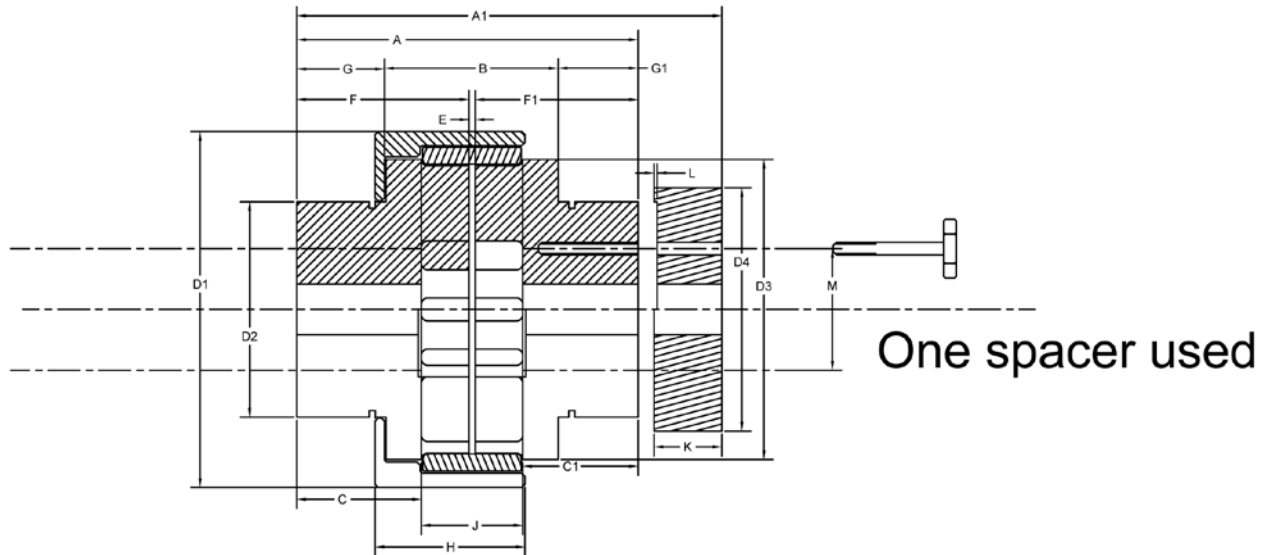

DOWNLOAD AVAILABLE CAD MODELS AT: [WWW.HUBCITYINC.COM](http://WWW.HUBCITYINC.COM)

Certified prints are available upon request

CALL: (605) 225-0360 • FAX: (605) 225-0567

# Hub City HubFlex® Coupling Spacer Coupling Dimensions

## HubFlex® Spacer Coupling Dimensions with Standard Cover

COUPLING SERIES	PILOT BORE DIAMETER	MAXIMUM BORE SIZE	MAXIMUM RPM	MAXIMUM TORQUE (IN-LBS)**	DBSE (DISTANCE BETWEEN SHAFT ENDS)	A	A1	A2	B	D1	D2	D3	D4	C	C1
HF10	1/2	1	3600	210	1-1/4"	2.59	3.87	N/A	1.03	2.49	2.00	2.07	2.55	1.08	0.87
HF10	1/2	1	3600	210	1-3/4"	2.80	4.08	N/A	1.03	2.49	2.00	2.07	2.55	1.08	1.08
HF10	1/2	1	3600	210	2-1/2" ‡	2.38	N/A	4.93	1.03	2.49	2.00	2.07	2.55	0.87	0.87
HF10	1/2	1	3600	210	3-1/8"	2.80	N/A	5.35	1.03	2.49	2.00	2.07	2.55	1.08	1.08
HF20	1/2	1-1/8"	3600	525	1-3/4" √	3.45	4.73	N/A	1.28	3.16	2.31	2.55	2.55	1.25	1.34
HF20	1/2	1-1/8"	3600	525	2-1/2" √	3.54	4.82	N/A	1.28	3.16	2.31	2.55	2.55	1.34	1.34
HF20	1/2	1-1/8"	3600	525	3-1/2" ***	3.36	N/A	5.91	1.28	3.16	2.31	2.55	2.55	1.25	1.25
HF20	1/2	1-1/8"	3600	525	3-3/4" √	3.54	N/A	6.09	1.28	3.16	2.31	2.55	2.55	1.34	1.34
HF30	3/4	1-5/8"	3600	2801	2-1/2" √	4.86	6.61	N/A	2.00	4.21	3.19	3.37	3.41	1.81	1.81
HF30	3/4	1-5/8"	3600	2801	3-1/2" ***	3.38	N/A	6.87	2.00	4.21	3.19	3.37	3.41	1.07	1.07
HF30	3/4	1-5/8"	3600	2801	3-3/4" ***	3.62	N/A	7.11	2.00	4.21	3.19	3.37	3.41	1.19	1.19
HF30	3/4	1-5/8"	3600	2801	4" ***	3.88	N/A	7.37	2.00	4.21	3.19	3.37	3.41	1.32	1.32
HF30	3/4	1-5/8"	3600	2801	4-3/8" ***	4.24	N/A	7.73	2.00	4.21	3.19	3.37	3.41	1.50	1.50
HF30	3/4	1-5/8"	3600	2801	5" √	4.86	N/A	8.35	2.00	4.21	3.19	3.37	3.41	1.81	1.81
HF40	7/8	1-7/8"	3600	4202	3-1/2" ***	3.38	N/A	7.59	2.42	5.48	3.52	4.49	3.78	0.87	0.87
HF40	7/8	1-7/8"	3600	4202	4" ***	3.88	N/A	8.22	2.42	5.48	3.52	4.49	3.78	1.12	1.12
HF40	7/8	1-7/8"	3600	4202	4-3/8" ***	4.24	N/A	8.45	2.42	5.48	3.52	4.49	3.78	1.3	1.3
HF40	7/8	1-7/8"	3600	4202	5" ***	4.88	N/A	9.09	2.42	5.48	3.52	4.49	3.78	1.62	1.62
HF40	7/8	1-7/8"	3600	4202	6" √	5.88	N/A	10.09	2.42	5.48	3.52	4.49	3.78	2.12	2.12

COUPLING SERIES	E MIN	E MAX	F	F1	G	G1	H	J	K	L	M (BOLT CIRCLE)	N-BOLTS (CAP SCREWS 4 EA)	WT* (LBS) WITH/ STANDARD CVR
HF10	0.062	0.092	1.16	1.37	0.67	0.88	0.95	0.66	1.34	0.063	1.59	1/4-20 x 1.75	3.5
HF10	0.062	0.092	1.37	1.37	0.88	0.88	0.95	0.66	1.34	0.063	1.59	1/4-20 x 1.75	3.5
HF10	0.062	0.092	1.16	1.16	0.67	0.67	0.95	0.66	1.34	0.063	1.59	1/4-20 x 1.75	4.5
HF10	0.062	0.092	1.37	1.37	0.88	0.88	0.95	0.66	1.34	0.063	1.59	1/4-20 x 1.75	4.5
HF20	0.036	0.11	1.75	1.66	1.14	1.05	1.35	0.88	1.34	0.063	1.84	1/4-20 x 1.75	6.0
HF20	0.036	0.11	1.75	1.75	1.14	1.14	1.35	0.88	1.34	0.063	1.84	1/4-20 x 1.75	6.0
HF20	0.036	0.11	1.66	1.66	1.05	1.05	1.35	0.88	1.34	0.063	1.84	1/4-20 x 1.75	7.5
HF20	0.036	0.11	1.75	1.75	1.14	1.14	1.35	0.88	1.34	0.063	1.84	1/4-20 x 1.75	7.5
HF30	0.080	0.205	2.39	2.39	1.42	1.42	1.95	1.21	1.81	0.063	2.50	5/16-18 X 2.75	14.5
HF30	0.080	0.205	1.65	1.65	0.68	0.68	1.95	1.21	1.81	0.063	2.50	5/16-18 X 2.75	N/A
HF30	0.080	0.205	1.77	1.77	0.80	0.80	1.95	1.21	1.81	0.063	2.50	5/16-18 X 2.75	N/A
HF30	0.080	0.205	1.90	1.90	0.93	0.93	1.95	1.21	1.81	0.063	2.50	5/16-18 X 2.75	N/A
HF30	0.080	0.205	2.08	2.08	1.11	1.11	1.95	1.21	1.81	0.063	2.50	5/16-18 X 2.75	N/A
HF30	0.080	0.205	2.39	2.39	1.42	1.42	1.95	1.21	1.81	0.063	2.50	5/16-18 X 2.75	N/A
HF40	0.035	0.208	1.67	1.67	0.49	0.49	2.38	1.66	2.17	0.063	2.50	5/16-18 X 2.75	N/A
HF40	0.035	0.208	1.92	1.92	0.74	0.74	2.38	1.66	2.17	0.063	2.50	5/16-18 X 2.75	N/A
HF40	0.035	0.208	2.1	2.1	0.92	0.92	2.38	1.66	2.17	0.063	2.50	5/16-18 X 2.75	N/A
HF40	0.035	0.208	2.42	2.42	1.24	1.24	2.38	1.66	2.17	0.063	2.50	5/16-18 X 2.75	N/A
HF40	0.035	0.208	2.92	2.92	1.74	1.74	2.38	1.66	2.17	0.063	2.50	5/16-18 X 2.75	22.5

Additional Sizes Available on Request

\*All weights shown are approximate for a complete spacer coupling assembly.

\*\* Maximum torque values (in-lbs) are based on use with green insert. Refer to page 12 for complete torque ratings.

\*\*\* For this size we recommend split cover

‡ To replace insert, move spacer back

√ CM or SM series Cover Required for these sizes.

DOWNLOAD AVAILABLE CAD MODELS AT: [WWW.HUBCITYINC.COM](http://WWW.HUBCITYINC.COM)

**Certified prints are available upon request**

EMAIL: [hubsales@regalbeloit.com](mailto:hubsales@regalbeloit.com) • [www.hubcityinc.com](http://www.hubcityinc.com)





# Hub City HubFlex® Coupling

## Spacer Coupling Dimensions

### HubFlex® Spacer Coupling Dimensions with Split (XH) Cover

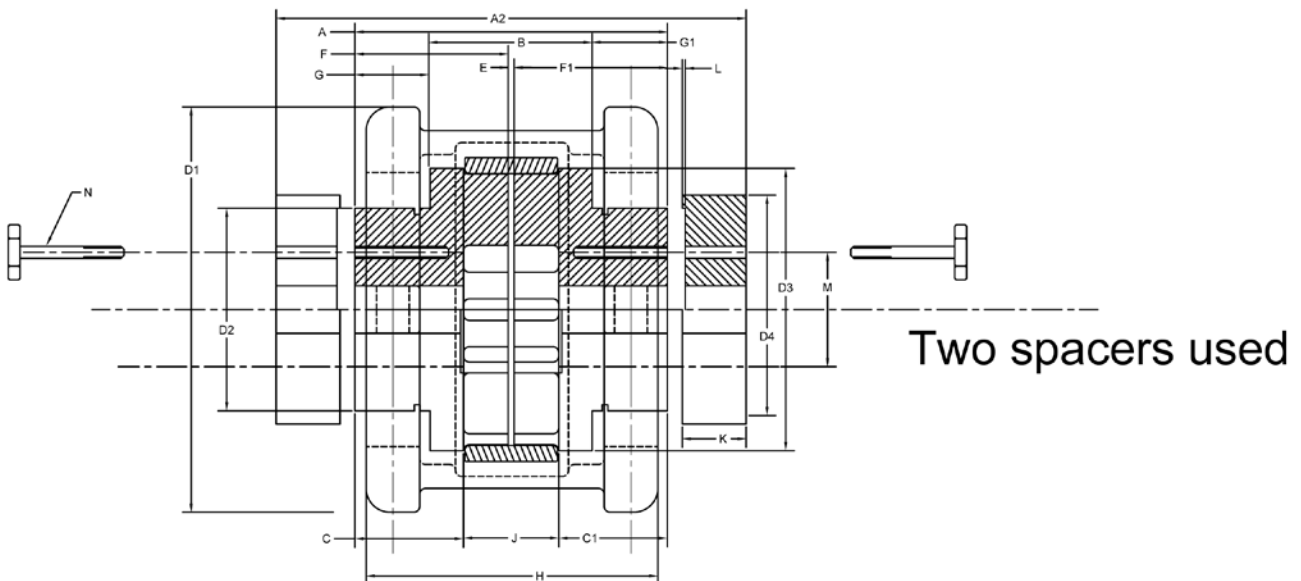
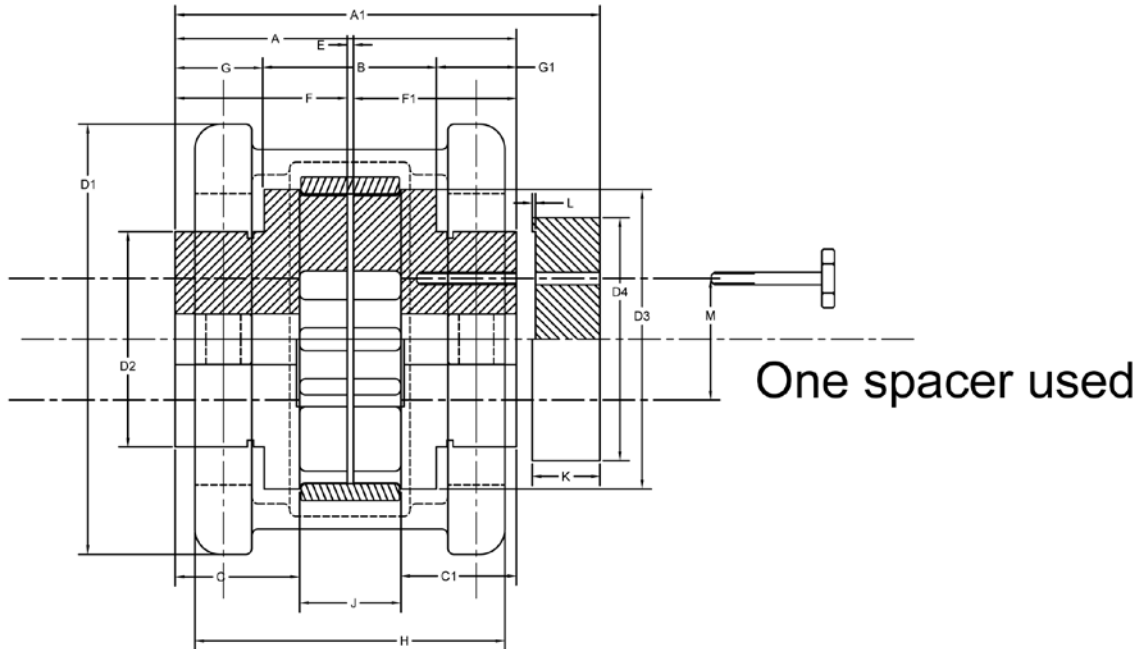

DOWNLOAD AVAILABLE CAD MODELS AT: [WWW.HUBCITYINC.COM](http://WWW.HUBCITYINC.COM)

Certified prints are available upon request

CALL: (605) 225-0360 • FAX: (605) 225-0567

# Hub City HubFlex® Coupling Spacer Coupling Dimensions

## HubFlex® Spacer Coupling Dimensions with Split (XH) Cover

COUPLING SERIES	PILOT BORE DIAMETER	MAXIMUM BORE SIZE	MAXIMUM RPM	MAXIMUM TORQUE (IN-LBS)**	DBSE (DISTANCE BETWEEN SHAFT ENDS)	A	A1	A2	B	D1	D2	D3	D4	C	C1
HF20	1/2	1-1/8"	3600	525	1-3/4"	3.45	4.73	N/A	1.28	3.99	2.31	2.55	2.55	1.25	1.34
HF20	1/2	1-1/8"	3600	525	2-1/2"	3.54	4.82	N/A	1.28	3.99	2.31	2.55	2.55	1.34	1.34
HF20	1/2	1-1/8"	3600	525	3-1/2" ***	3.36	N/A	5.91	1.28	3.99	2.31	2.55	2.55	1.25	1.25
HF20	1/2	1-1/8"	3600	525	3-3/4" ***	3.54	N/A	6.09	1.28	3.99	2.31	2.55	2.55	1.34	1.34
HF30	3/4	1-5/8"	3600	2801	2-1/2"	4.86	6.61	N/A	2.00	5.34	3.19	3.37	3.41	1.81	1.81
HF30	3/4	1-5/8"	3600	2801	3-1/2" ***	3.38	N/A	6.87	2.00	5.34	3.19	3.37	3.41	1.07	1.07
HF30	3/4	1-5/8"	3600	2801	3-3/4" ***	3.62	N/A	7.11	2.00	5.34	3.19	3.37	3.41	1.19	1.19
HF30	3/4	1-5/8"	3600	2801	4" ***	3.88	N/A	7.37	2.00	5.34	3.19	3.37	3.41	1.32	1.32
HF30	3/4	1-5/8"	3600	2801	4-3/8" ***	4.24	N/A	7.73	2.00	5.34	3.19	3.37	3.41	1.50	1.50
HF30	3/4	1-5/8"	3600	2801	5"	4.86	N/A	8.35	2.00	5.34	3.19	3.37	3.41	1.81	1.81
HF40	7/8	1-7/8"	3600	4202	3-1/2" ***	3.38	N/A	7.59	2.42	7.28	3.52	4.49	3.78	0.87	0.87
HF40	7/8	1-7/8"	3600	4202	4" ***	3.88	N/A	8.22	2.42	7.28	3.52	4.49	3.78	1.12	1.12
HF40	7/8	1-7/8"	3600	4202	4-3/8" ***	4.24	N/A	8.45	2.42	7.28	3.52	4.49	3.78	1.3	1.3
HF40	7/8	1-7/8"	3600	4202	5" ***	4.88	N/A	9.09	2.42	7.28	3.52	4.49	3.78	1.62	1.62
HF40	7/8	1-7/8"	3600	4202	6"	5.88	N/A	10.09	2.42	7.28	3.52	4.49	3.78	2.12	2.12

COUPLING SERIES	E MIN	E MAX	F	F1	G	G1	H	J	K	L	M (BOLT CIRCLE)	N- BOLTS (CAP SCREWS 4 EA)	WT* (LBS) WITH/ SPLIT CVR
HF20	0.036	0.11	1.75	1.66	1.14	1.05	1.93	0.88	1.34	0.063	1.84	1/4-20 x 1.75	6.5
HF20	0.036	0.11	1.75	1.75	1.14	1.14	1.93	0.88	1.34	0.063	1.84	1/4-20 x 1.75	6.5
HF20	0.036	0.11	1.66	1.66	1.05	1.05	1.93	0.88	1.34	0.063	1.84	1/4-20 x 1.75	8.0
HF20	0.036	0.11	1.75	1.75	1.14	1.14	1.93	0.88	1.34	0.063	1.84	1/4-20 x 1.75	8.0
HF30	0.080	0.205	2.39	2.39	1.42	1.42	2.61	1.21	1.81	0.063	2.50	5/16-18 X 2.75	15.0
HF30	0.080	0.205	1.65	1.65	0.68	0.68	2.61	1.21	1.81	0.063	2.50	5/16-18 X 2.75	18.5
HF30	0.080	0.205	1.77	1.77	0.80	0.80	2.61	1.21	1.81	0.063	2.50	5/16-18 X 2.75	18.5
HF30	0.080	0.205	1.90	1.90	0.93	0.93	2.61	1.21	1.81	0.063	2.50	5/16-18 X 2.75	18.5
HF30	0.080	0.205	2.08	2.08	1.11	1.11	2.61	1.21	1.81	0.063	2.50	5/16-18 X 2.75	18.5
HF30	0.080	0.205	2.39	2.39	1.42	1.42	2.61	1.21	1.81	0.063	2.50	5/16-18 X 2.75	18.5
HF40	0.035	0.208	1.67	1.67	0.49	0.49	3.02	1.66	2.17	0.063	2.50	5/16-18 X 2.75	31.0
HF40	0.035	0.208	1.92	1.92	0.74	0.74	3.02	1.66	2.17	0.063	2.50	5/16-18 X 2.75	31.0
HF40	0.035	0.208	2.1	2.1	0.92	0.92	3.02	1.66	2.17	0.063	2.50	5/16-18 X 2.75	31.0
HF40	0.035	0.208	2.42	2.42	1.24	1.24	3.02	1.66	2.17	0.063	2.50	5/16-18 X 2.75	31.0
HF40	0.035	0.208	2.92	2.92	1.74	1.74	3.02	1.66	2.17	0.063	2.50	5/16-18 X 2.75	25.0

Additional Sizes Available on Request

\*All weights shown are approximate for a complete spacer coupling assembly.

\*\* Maximum torque values (in-lbs) are based on use with green insert. Refer to page 12 for complete torque ratings.

\*\*\* For this size use split cover only

# Hub City HubFlex® Coupling

## Spacer Coupling Quick Selection

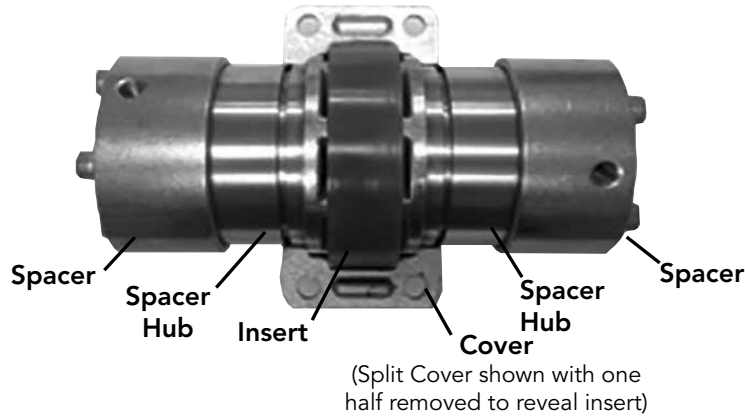

HP	DBSE	MAXIMUM BORE	STANDARD STOCK BORES	REQUIRED HUBS AND/OR SPACER HUBS		REQUIRED SPACER	INSERT	COVER
Up to 3HP	1-1/4"	1"	PB (1/2"), 5/8", 3/4", 7/8", 1"	HF10CS12SH (1 ea) and HF10CSXXXH (1 ea)	PLUS (+)	HF10CSXXXS (1 ea)	HF10SD-INS	HF10SD-CVR
Up to 3HP	1-3/4"	1"	PB (1/2"), 5/8", 3/4", 7/8", 1"	HF10CS14SH (1 ea) and HF10CSXXXH (1 ea)	PLUS (+)	HF10CSXXXS (1 ea)	HF10SD-INS	HF10SD-CVR
Up to 3HP	2-1/2"	1"	PB (1/2"), 5/8", 3/4", 7/8", 1"	HF10CS12SH (2 ea)	PLUS (+)	HF10CSXXXS (2 ea)	HF10SD-INS	HF10SD-CVR
Up to 3HP	3-1/8"	1"	PB (1/2"), 5/8", 3/4", 7/8", 1"	HF10CS14SH (2 ea)	PLUS (+)	HF10CSXXXS (2 ea)	HF10SD-INS	HF10SD-CVR
Up to 7.5HP	1-3/4"	1-1/8"	PB (1/2"), 5/8", 3/4", 7/8", 1", 1-1/8"	HF20CS17SH (1 ea) and HF20CSXXXH (1 ea)	PLUS (+)	HF20CSXXXS (1 ea)	HF20SD-INS	HF20CM/SM-CVR OR HF20XH-CVR
Up to 7.5HP	2-1/2"	1-1/8"	PB (1/2"), 5/8", 3/4", 7/8", 1", 1-1/8"	HF20CS18SH (1 ea) and HF20CSXXXH (1 ea)	PLUS (+)	HF20CSXXXS (1 ea)	HF20SD-INS	HF20CM/SM-CVR OR HF20XH-CVR
Up to 7.5HP	3-1/2"	1-1/8"	PB (1/2"), 5/8", 3/4", 7/8", 1", 1-1/8"	HF20CS17SH (2 ea)	PLUS (+)	HF20CSXXXS (2 ea)	HF20SD-INS	HF20XH-CVR
Up to 7.5HP	3-3/4"	1-1/8"	PB (1/2"), 5/8", 3/4", 7/8", 1", 1-1/8"	HF20CS18SH (2 ea)	PLUS (+)	HF20CSXXXS (2 ea)	HF20SD-INS	HF20CM/SM-CVR OR HF20XH-CVR
Up to 40HP	2-1/2"	1-5/8"	PB (3/4"), 7/8", 1", 1-1/8", 1-1/4", 1-3/8", 1-1/2", 1-5/8"	HF30CS24SH (1 ea) and HF30CSXXXH (1 ea)	PLUS (+)	HF30CSXXXS (1 ea)	HF30SD-INS	HF30CM/SM-CVR OR HF30XH-CVR
Up to 40HP	3-1/2"	1-5/8"	PB (3/4"), 7/8", 1", 1-1/8", 1-1/4", 1-3/8", 1-1/2", 1-5/8"	HF30CS17SH (2 ea)	PLUS (+)	HF30CSXXXS (2 ea)	HF30SD-INS	HF30XH-CVR
Up to 40HP	3-3/4"	1-5/8"	PB (3/4"), 7/8", 1", 1-1/8", 1-1/4", 1-3/8", 1-1/2", 1-5/8"	HF30CS18SH (2 ea)	PLUS (+)	HF30CSXXXS (2 ea)	HF30SD-INS	HF30XH-CVR
Up to 40HP	4"	1-5/8"	PB (3/4"), 7/8", 1", 1-1/8", 1-1/4", 1-3/8", 1-1/2", 1-5/8"	HF30CS19SH (2 ea)	PLUS (+)	HF30CSXXXS (2 ea)	HF30SD-INS	HF30XH-CVR
Up to 40HP	4-3/8"	1-5/8"	PB (3/4"), 7/8", 1", 1-1/8", 1-1/4", 1-3/8", 1-1/2", 1-5/8"	HF30CS21SH (2 ea)	PLUS (+)	HF30CSXXXS (2 ea)	HF30SD-INS	HF30XH-CVR
Up to 40HP	5"	1-5/8"	PB (3/4"), 7/8", 1", 1-1/8", 1-1/4", 1-3/8", 1-1/2", 1-5/8"	HF30CS24SH (2 ea)	PLUS (+)	HF30CSXXXS (2 ea)	HF30SD-INS	HF30CM/SM-CVR OR HF30XH-CVR
Up to 60HP	3-1/2"	1-7/8"	PB (7/8"), 1", 1-1/8", 1-3/8", 1-1/2", 1-5/8", 1-3/4", 1-7/8"	HF40CS17SH (2 ea)	PLUS (+)	HF40CSXXXS (2 ea)	HF40SD-INS	HF40XH-CVR
Up to 60HP	4"	1-7/8"	PB (7/8"), 1", 1-1/8", 1-3/8", 1-1/2", 1-5/8", 1-3/4", 1-7/8"	HF40CS19SH (2 ea)	PLUS (+)	HF40CSXXXS (2 ea)	HF40SD-INS	HF40XH-CVR
Up to 60HP	4-3/8"	1-7/8"	PB (7/8"), 1", 1-1/8", 1-3/8", 1-1/2", 1-5/8", 1-3/4", 1-7/8"	HF40CS21SH (2 ea)	PLUS (+)	HF40CSXXXS (2 ea)	HF40SD-INS	HF40XH-CVR
Up to 60HP	5"	1-7/8"	PB (7/8"), 1", 1-1/8", 1-3/8", 1-1/2", 1-5/8", 1-3/4", 1-7/8"	HF40CS24SH (2 ea)	PLUS (+)	HF40CSXXXS (2 ea)	HF40SD-INS	HF40XH-CVR
Up to 60HP	6"	1-7/8"	PB (7/8"), 1", 1-1/8", 1-3/8", 1-1/2", 1-5/8", 1-3/4", 1-7/8"	HF40CS29SH (2 ea)	PLUS (+)	HF40CSXXXS (2 ea)	HF40SD-INS	HF40CM/SM-CVR OR HF40XH-CVR

DOWNLOAD AVAILABLE CAD MODELS AT: [WWW.HUBCITYINC.COM](http://WWW.HUBCITYINC.COM)

Certified prints are available upon request

CALL: (605) 225-0360 • FAX: (605) 225-0567

# Hub City HubFlex® Coupling

## Service Factors

### HubFlex® Couplings Service Factors

Application . . . . .	Service Factor
Aerators . . . . .	2.50
Aggregate Processing, Cement, Mining Kilns	
Direct or on Line Shaft of Reducer	
With Final Drive Machined Spur Gears . . . . .	2.25
With Single Helical or Herringbone Gears . . . . .	2.00
Crushers, Ore or Stone . . . . .	2.75
Dryer, Rotary . . . . .	2.00
Grizzly . . . . .	2.25
Hammermill or Hog . . . . .	2.00
Tumbling Mill or Barrel . . . . .	2.00
Agitators	
Vertical, Horizontal, Screw, Propeller, Paddle . . . . .	1.25
Barge Haul Puller . . . . .	1.75
Blowers	
Centrifugal . . . . .	1.50
Lobe or Vane . . . . .	1.50
Brewing and Distilling	
Bottle and Can Filling Machines . . . . .	1.50
Brew Kettle . . . . .	1.25
Cookers, Continuous Duty . . . . .	1.50
Lauter Tub . . . . .	1.75
Mash Tub . . . . .	1.50
Scale Hopper, Frequent Peaks . . . . .	2.00
Clarifier Or Classifier . . . . .	1.25
Clay Working Industry	
Brick Press, Briquette Machine, Clay Working Machine, Pug Mill . . . . .	2.00
Compressors	
Centrifugal . . . . .	1.25
Rotary, Lobe or Vane . . . . .	1.50
Rotary, Screw . . . . .	1.50
Reciprocating	
Direct Connected . . . . .	Refer to Factory
Without Flywheels . . . . .	Refer to Factory
With Flywheel and Gear between Compressor and Prime Monitor	
1 Cylinder, Single Acting . . . . .	3.00
1 Cylinder, Double Acting . . . . .	3.00
2 Cylinders, Single Acting . . . . .	3.00
2 Cylinders Double Acting . . . . .	3.00
3 Cylinders Single Acting . . . . .	3.00
3 Cylinders, Double Acting . . . . .	2.00
4 Or More Cyl. Single Acting . . . . .	2.50
4 Or More Cyl. Double Acting . . . . .	2.50
Conveyors	
Apron, Assembly, Belt, Chain, Flight, Screw . . . . .	1.75
Bucket . . . . .	1.75
Live Roll, Shaker and Reciprocating . . . . .	3.00
Bridge, Travel or Trolley . . . . .	2.50
Dredgers	
Cable Reel . . . . .	2.00
Conveyors . . . . .	1.50

\* For reversing applications with high inertia loads, please Consult Factory.

DOWNLOAD AVAILABLE CAD MODELS AT: [WWW.HUBCITYINC.COM](http://WWW.HUBCITYINC.COM)

**Certified prints are available upon request**

**EMAIL: [hubsales@regalbeloit.com](mailto:hubsales@regalbeloit.com) • [www.hubcityinc.com](http://www.hubcityinc.com)**

Application . . . . .	Service Factor
Cutter Head, Jig Drive . . . . .	2.50
Maneuvering Winch . . . . .	1.75
Pumps (Uniform Load) . . . . .	1.75
Screen Drive, Stacker . . . . .	2.00
Utility Winch . . . . .	2.00
Dynamometer . . . . .	1.50
Elevators - Bucket, Centrifugal Discharge . . . . .	1.75
Exciter, Generator . . . . .	1.50
Extruder, Plastic . . . . .	1.50
Fans	
Centrifugal . . . . .	1.25
Cooing Tower . . . . .	2.00
Forced Draft-Across the Line Start . . . . .	1.75
Food Industry	
Beet Slicer . . . . .	2.00
Bottling, Can, Filling Machine . . . . .	1.50
Cereal Cooker . . . . .	1.50
Dough Mixer, Meat Grinder . . . . .	2.00
Forced Draft Motor driven thru fluid or Electric Slip Clutch . . . . .	1.25
Gas Recirculating . . . . .	1.50
Induced Draft with damper control or blade cleaner . . . . .	1.50
Induced Draft without controls . . . . .	2.00
Feeders	
Apron, Belt, Disc, Screw . . . . .	1.25
Reciprocating . . . . .	2.50
Generators	
Even Load . . . . .	1.25
Hoist or Railway Service . . . . .	1.75
Welder Load . . . . .	2.00
Hammermill . . . . .	1.75
Laundry Washer Or Tumbler . . . . .	2.00
Line Shafts Any Processing Machinery . . . . .	1.50
Lumber	
Band Resaw . . . . .	2.00
Circular Resaw, Cutoff . . . . .	2.00
Edger, Head Rig, Hog . . . . .	2.50
Gang Saw (Reciprocating) . . . . .	3.00
Log Haul . . . . .	2.50
Planer . . . . .	2.00
Rolls, Non-Reversing . . . . .	1.50
Rolls, Reversing . . . . .	2.50
Sawdust Conveyor . . . . .	1.50
Slab Conveyor . . . . .	2.00
Sorting Table . . . . .	1.75
Trimmer . . . . .	2.00
Machine Tools	
Auxiliary and Traverse Drive . . . . .	1.00

# Hub City HubFlex® Coupling

## Service Factors

### HubFlex® Couplings Service Factors

Application	Service Factor
Bending Roll, Notching Press, Punch, Press, Planer, Plate Reversing	1.75
Main Drive	1.50
Metal Rolling Mills	
Coilers (Up or Down) Cold Mill Only	1.75
Coilers (Up or Down) Hot Mill Only	2.25
Coke Plants	
Pusher Ram Drive	2.75
Door Opener	2.25
Pusher or Larry Car Traction Drive	3.25
Continuous Caster	2.00
Cold Mills	
Strip Mills	Refer to Factory
Temper Mills	Refer to Factory
Cooling Beds	1.75
Drawbench	2.25
Feed Rolls - Blooming Mills	3.25
Furnace Pushers	2.25
Hot and Cold Saws	2.25
Hot Mills	
Strip or Sheet Mills	Refer to Factory
Reversing Blooming	Refer to Factory
Slabbing Mills	Refer to Factory
Edger Drives	Refer to Factory
Ingot Cars	2.25
Manipulators	3.25
Merchant Mills	Refer to Factory
Mill Tables	
Roughing Breakdown Mills	3.25
Hot Bed or Transfer (non-reversing)	1.75
Runout (reversing)	3.25
Runout (non-reversing, non-plugging)	2.25
Reel Drives	2.00
Rod Mills	Refer to Factory
Screwdown	2.25
Seamless Tube Mills	
Piercer	3.25
Thrust Block	2.25
Tube Conveyor Rolls	2.25
Reeler	2.25
Kick Out	2.25
Shear, Croppers	Refer to Factory
Sideguards	3.25
Skelp Mills	Refer to Factory
Slitters (Steel Mill only)	2.00
Soaking Pit Cover Drives	
Lift	1.25
Travel	2.25
Straighteners	2.25
Unscramblers (Billet Bundle Busters)	2.25
Wire Drawing Machinery	2.00
Mixers (also see Agitators)	
Concrete	1.75
Muller	1.50

\* For reversing applications with high inertia loads, please Consult Factory.

Application	Service Factor
Oil Industry	
Chiller	1.50
Oilwell Pumping (not over 150% peak torque)	2.50
Paraffin Filter Press	1.75
Rotary Kiln	2.50
Paper Mills	
Barker, Auxiliary, Hydraulic	2.50
Barker, Mechanical	2.50
Barker, Drum L.S. shaft of reducer with final drive-	
Helical or Herringbone Gear	5.00
Machined Spur Gear	3.00
Cast Tooth Spur Gear	3.00
Beater & Pulper	2.00
Bleachers, Coaters	1.50
Calendar & Super Calendar	2.00
Chipper	3.00
Converting Machine	1.50
Couch	2.00
Cutter, Felt Whipper	2.25
Cylinder, Dryer	2.00
Felt Stretcher	1.75
Fourdriner	2.00
Jordan	2.50
Log Haul	2.50
Line Shaft	1.75
Press	2.00
Pulp Grinder	2.00
Reel, Rewinder, Winder	2.00
Stock Chest, Washer, Thickener	1.75
Stock Pumps, Centrifugal	
Constant Speed	1.25
Frequent Speed Changes Under Load	1.50
Suction Roll	2.00
Press, Printing	1.50
Pug Mill	1.75
Pulverizers	
Hammermill and Hog	1.75
Roller	1.50
Pumps Centrifugal	
Constant Speed	1.00
Frequent Speed Changes Under Load	1.75
Descaling, with Accumulators	1.75
Gear, Rotary, or Vane	1.75
Pumps Reciprocating	
1 Cyl., single or double acting	3.00
2 Cyl., single acting	2.50
2 Cyl., double acting	2.00
3 or more cylinders	2.00

DOWNLOAD AVAILABLE CAD MODELS AT: [WWW.HUBCITYINC.COM](http://WWW.HUBCITYINC.COM)

**Certified prints are available upon request**

**CALL: (605) 225-0360 • FAX: (605) 225-0567**

# Hub City HubFlex® Coupling

## Service Factors

### HubFlex® Couplings Service Factors

Application . . . . .	Service Factor
<b>Rubber Industry</b>	
Calendar . . . . .	2.25
Cracker, Plasticolour . . . . .	2.50
Extruder . . . . .	2.00
Tire & Tube Press Opener (peak torque) . . . . .	1.50
<b>Warming Mill</b>	
One or two mills in line . . . . .	2.00
Three or more mills in line . . . . .	2.50
Washer . . . . .	2.75
<b>Screens</b>	
Air Washing . . . . .	1.50
Grizzly . . . . .	2.50
Rotary Coal or Sand . . . . .	2.00
Vibrating . . . . .	2.50
Water . . . . .	1.50
<b>Sewage Disposal Equipment</b>	
Bar Screen, Chemical Feeders, Collectors,	
Dewatering Screen, Grit Collector . . . . .	1.50
Mill Stands, Turbine Driven with all Helical or Herringbone Gears . . . . .	1.75
Electric Drive or Steam Engine Drive with Helical or Herringbone . . . . .	2.00
Stoker . . . . .	1.00
<b>Sugar Industry</b>	
Cone Carrier and Leveler . . . . .	2.25
Cane Knife and Crusher . . . . .	2.50
Mill Stands, Turbine Driver with all helical or Herringbone Gears . . . . .	1.75
Electric Drive or Steam Engine Drive with helical, Herringbone, or Spur Gears with any Prime Mover . . . . .	2.00
<b>Textile Industry</b>	
Batcher . . . . .	1.50
Calendar, Card Machine . . . . .	1.75
Cloth Finishing Machine . . . . .	1.75
Dry Can, Loom . . . . .	1.75
Dyeing Machinery . . . . .	1.50
Knitting Machine . . . . .	Refer to Factory
Mangle, Napper, Soaper . . . . .	1.50
Spinner, Tenter Frame, Winder . . . . .	1.75
Tumbling Barrel . . . . .	2.00
Winch, Maneuvering - Dredge, Marine . . . . .	1.50
Windlass . . . . .	1.50

\* For reversing applications with high inertia loads, please Consult Factory.

### Engine Service Factors

Service Factors for engine drives are those required for applications where good flywheel regulation prevents torque fluctuation greater than 20%. For drives where torque fluctuations are greater or where the operation is near a serious critical or torsional vibration, a mass elastic study is necessary.

To determine an engine drive service factor, first determine the application service factor for motors. Then, use that to find the correct engine service factor in the table below. When the application service factor for motors is greater than 2.0 or where 1, 2, or 3 cylinder engines are involved, please contact customer service with complete application details for engineering review.

APPLICATION SERVICE FACTOR	ENGINE FACTOR	
	4 TO 5 CYLINDERS	6+ CYLINDERS
1.00	2.000	1.500
1.25	2.250	1.750
1.50	2.500	2.000
1.75	2.750	2.250
2.00	3.000	2.500

# Hub City HubFlex® Coupling

## Compatibility Chart

A = Little to No Effect; B = Minor to Moderate Effect; C = Severe Effect to Destruction; N = No Data; Test Prior to Use

Acetaldehyde . . . . . C	Bleach Solutions . . . . . N	Freon, 12 or 113 . . . . . A	Paimitic Acid . . . . . A
Acetamide . . . . . N	Boric Acid . . . . . A	Fuel Oil . . . . . B	Paint Thinner . . . . . B
Acetic Acid . . . . . C	Brake Fluid . . . . . N	Gasoline . . . . . B	Peanut Oil . . . . . A
Acetic Anhydride . . . . . C	Bromine . . . . . B	Glucose . . . . . A	Perchloric Acid . . . . . C
Acetone . . . . . C	Bunker Oil . . . . . A	Glue . . . . . N	Perchloroethylene . . . . . C
Acetyl Bromide . . . . . C	Butane . . . . . A	Glycerin . . . . . A	Petroleum . . . . . B
Acetyl Chloride . . . . . C	Butyl Acetate . . . . . C	Heptane . . . . . A	Phenol (carbolic acid) . . . . . C
Acetylene . . . . . C	Butyl Alcohol . . . . . B	Hexane . . . . . A	Phosphoric Acid . . . . . C
Adipic Acid . . . . . A	Calcium Carbonate . . . . . B	Hydrazine . . . . . C	Potassium Cyanide . . . . . A
Aero Shell Grease . . . . . B	Calcium Chloride . . . . . A	Hydrobromic Acid . . . . . B	Potassium Salts . . . . . B
Aero Lubriplate . . . . . A	Calcium Hydroxide . . . . . A	Hydrocarbon Oil . . . . . A	Propane . . . . . B
Aero Safe 2300 . . . . . N	Calcium Nitrate . . . . . B	Hydrochloric Acid . . . . . B	Propyl Alcohol . . . . . B
Aerocene 50 . . . . . N	Calcium Sulfate . . . . . B	Hydrofluoric Acid . . . . . B	Propylene Glycol . . . . . B
Aluminum Acetate . . . . . N	Carbon Dioxide . . . . . A	Hydrogen . . . . . A	Pydraul Oil . . . . . C
Aluminum Bromide . . . . . N	Carbon Disulfide . . . . . B	Hydrogen Peroxide . . . . . B	SAE #10 Oil . . . . . A
Aluminum Chloride . . . . . B	Carbon Monoxide . . . . . A	Hydrogen Sulfide . . . . . C	Seawater . . . . . A
Aluminum Sulfate . . . . . B	Carbon Tetrachloride . . . . . C	Hydrologic Acid . . . . . B	Silicic Acid . . . . . B
Ammonia . . . . . B	Chlorine . . . . . N	Iodine . . . . . A	Silver Nitrate . . . . . B
Ammonium Carbonate . . . . . B	Chloroacetic Acid . . . . . C	Isobutyl Alcohol . . . . . N	Skydrol Oil . . . . . C
Ammonium Chloride . . . . . N	Chloroform . . . . . C	Isopropyl Chloride . . . . . N	Soap . . . . . B
Ammonium Hydroxide . . . . . B	Chromic Acid . . . . . C	Isopropyl Ether . . . . . B	Sodium Acetate . . . . . A
Ammonium Nitrate . . . . . B	Chromium Potassium Sulfate . . . . . B	Isopropyl Alcohol (Propanol) . . . . . B	Sodium Bicarbonate . . . . . B
Ammonium Persulfate . . . . . B	Citric Acid . . . . . B	JP4 Oil . . . . . B	Sodium Borate . . . . . B
Ammonium Sulfate . . . . . B	Corn Oil . . . . . A	JP5 & 6 Oil . . . . . C	Sodium Carbonate . . . . . B
Ammonium Sulfide . . . . . B	Cottonseed Oil . . . . . A	Kerosene . . . . . B	Sodium Chloride . . . . . B
Ammonium Thiocyanate . . . . . B	Cresol . . . . . C	Lactic Acid . . . . . B	Sodium Cyanide . . . . . B
Amonnium Acetate . . . . . C	Crude Oil . . . . . B	Lead Acetate . . . . . B	Sodium Hydrosulfite . . . . . B
Amyl Acetate . . . . . C	Cupric Chloride . . . . . A	Linseed Oil . . . . . B	Sodium Hydroxide . . . . . B
Amyl Alcohol . . . . . C	Cupric Nitrate . . . . . B	Liquefied Petroleum Gas . . . . . A	Sodium Hypochlorite . . . . . C
Aniline . . . . . C	Cupric Sulfate . . . . . B	Lubrication Oil . . . . . B	Sodium Nitrate . . . . . B
Aniline Hydrochloride . . . . . C	Cutting Oil . . . . . B	Lye . . . . . N	Sodium Silicate . . . . . A
Animal Fats & Oils . . . . . B	Cyclohexane . . . . . B	Magnesium Chloride . . . . . N	Sodium Sulfate . . . . . B
Antimony Salts . . . . . B	Cyclohexanone . . . . . C	Magnesium Hydroxide . . . . . A	Sodium Sulfide . . . . . B
Aqua Regia . . . . . C	Dibutyl Phthalate . . . . . C	Magnesium Salts . . . . . B	Steam . . . . . C
Arsenic Salts . . . . . B	Dichlorobenzene . . . . . C	Malaic Acid . . . . . C	Styrene . . . . . B
ASTM Oil #1 . . . . . A	Diesel Fuel . . . . . B	Mercury . . . . . B	Sulfur Dioxide . . . . . B
ASTM Oil #2 . . . . . B	Diester Oil . . . . . B	Methyl Alcohol (methanol) . . . . . A	Sulfuric Acid . . . . . C
ASTM Oil #3 . . . . . B	Dimethyl Acetamide . . . . . C	Methyl Ethyl Ketone . . . . . C	Tannic Acid . . . . . A
ASTM Reference Fuel . . . . . A	Dimethyl Formamide . . . . . C	Methylene Chloride . . . . . C	Tartaric Acid . . . . . A
ASTM Reference Fuel . . . . . B	Dodecyl Mercaptan . . . . . B	MIL-D-5606 Oil . . . . . C	Toluene . . . . . C
Atlantic Oil . . . . . A	DTE Oil . . . . . B	MIL-L-7808 Oil . . . . . B	Transformer Oil . . . . . B
Barium Carbonate . . . . . B	Dibutyl Ether . . . . . B	Mineral Oil . . . . . A	Turpentine . . . . . C
Barium Hydroxide . . . . . A	EP Lubes . . . . . A	Mineral Spirits . . . . . N	Urea . . . . . B
Beer . . . . . A	Esso #90 Lube Oil . . . . . A	Naphthalene . . . . . B	Varnish . . . . . B
Benzaldehyde . . . . . B	Ether . . . . . B	Natural Gas . . . . . B	Water . . . . . B
Benzene . . . . . C	Ethyl Acetate . . . . . C	Nickel Salts . . . . . C	
Benzoic Acid . . . . . B	Ethyl Alcohol (Ethanol) . . . . . C	Oxygen . . . . . A	
Black Sulphate Liquors . . . . . N	Formic Acid . . . . . C	Ozone . . . . . A	

DOWNLOAD AVAILABLE CAD MODELS AT: [WWW.HUBCITYINC.COM](http://WWW.HUBCITYINC.COM)

**Certified prints are available upon request**

**CALL: (605) 225-0360 • FAX: (605) 225-0567**



# Hub City HubFlex® Coupling

## Safety Guidelines

When using HubFlex® Couplings, you must follow the installation instructions and take the following precautions. Failure to do so may cause the HubFlex® Coupling(s) to break and parts to be thrown with sufficient force to cause severe injury or death.



Refer to this catalog for proper selection, sizing, horsepower, torque range, and speed range of HubFlex® Couplings. Follow the installation instructions included with the product. Do not exceed catalog ratings.

During start up and operation of HubFlex® Couplings, avoid sudden shock loads. HubFlex® Coupling assembly should operate quietly and smoothly. If HubFlex® Coupling assembly vibrates or makes beating sound, shut down immediately, and recheck alignment. Shortly after initial operation and periodically thereafter, where applicable, inspect HubFlex® Coupling assembly for: alignment, wear of elastomeric element, and flexing elements for signs of fatigue. Do not operate HubFlex® Coupling assembly if alignment is improper, or if elastomeric element is damaged or worn.

Do not use any HubFlex® Couplings for elevators, man lifts, or other devices that carry people. If the HubFlex® Coupling fails, the lift device could fall resulting in severe injury or death.

For all HubFlex® Couplings, you must install suitable guards in accordance with OSHA and American Society of Mechanical Engineers Standards. Do not start HubFlex® Coupling before suitable guards are in place. Failure to properly guard these products may result in severe injury or death from personnel contacting moving parts or from parts being thrown from assembly in the event the HubFlex® Coupling product fails.

If you have any questions, contact your Hub City Sales Representative - [www.hubcityinc.com](http://www.hubcityinc.com).

# Hub City HubFlex® Coupling

## Quick Selection Guide



### Insert Features

Standard duty (Orange)	Medium Duty (Green)	Extreme Duty (Black)	High Temp (Gray)	Food Grade (White)
Max Temp: 200 F	Max Temp: 200 F	Max Temp: 200 F	Max Temp: 300 F	Max Temp: 200 F
Greatest Dampening Lowest Torque	Lower Dampening Higher Torque	Lowest Dampening Highest Torque	Dampening & Torque Same as Green	Dampening & Torque Same as Orange FDA Approved Material

### MAX TORQUE RATING (in. lbs.) With STANDARD Cover

MAX BORE	COUPLING SERIES	ORANGE	GREEN	BLACK	HI-TEMP	FOOD GRADE
1-1/4"	HF10	365	792	792	792	365

### MAX TORQUE RATING (in. lbs.) With EXTREME DUTY Cover

MAX BORE	COUPLING SERIES	ORANGE	GREEN	BLACK	HI-TEMP	FOOD GRADE
1-5/8"	HF20	1254	2457	3789	2457	1254
2-1/8"	HF30	4099	7730	11914	7730	4099
2-3/8"	HF40	8630	17099	25870	17099	8630
3"	HF50	17315	34336	52408	34336	17315
3-7/8"	HF60	30353	58137	87110	58137	30353
4-1/8"	HF70	38048	75538	116432	75538	38048

Estimated Torque Ratings for Additional Sizes Available Upon Request - Consult Factory

4-1/2"	HF80	75000	145000	220000	145000	75000
5-1/2"	HF90	105000	204000	310000	204000	105000
7"	HF100	175000	345000	550000	345000	175000
8"	HF110	300000	565000	870000	565000	300000
11"	HF120	NA	1120000	1680000	1120000	NA

DOWNLOAD AVAILABLE CAD MODELS AT: [WWW.HUBCITYINC.COM](http://WWW.HUBCITYINC.COM)

**Certified prints are available upon request**

**CALL: (605) 225-0360 • FAX: (605) 225-0567**