

# Hub City ModuLine® Spherical Roller Bearing Units



ModuLine® Spherical Roller Bearing Features . . . . .	P-2
ModuLine® Spherical Roller Bearing Engineering & Selection . . .	P-4
ModuLine® Pillow Block Dimensions (Traditional Straight Bore Parameters) . . . . .	P-10
ModuLine® Flange Block Dimensions (Traditional Straight Bore Parameters) . . . . .	P-12
ModuLine® Pillow Block Dimensions (Type E Dimensional Equivalent) . . . . .	P-13
ModuLine® Flange Block Dimensions (Type E Dimensional Equivalent) . . . . .	P-15
ModuLine® Spherical Roller Bearing Accessories . . . . .	P-16
ModuLine® Spherical Roller Bearing Modified and Custom Design Capabilities . . . . .	P-18

# Hub City ModuLine® Spherical Roller Bearing Units

## Features and Benefits

- Modular design
- High Load Capacity
- Tolerates Misalignment up to 1-1/2°
- Mechanically and dimensionally interchangeable with most major brands
- Housing dimensions to match both Type-E and traditional straight bore units
- Pillow block housings are machined at each end to ease alignment at installation
- Three sealing options to guard against contamination
- Double Lip or Triple Lip Nitrile contact seals, Teflon Labyrinth seals
- Inserts - 52100 bearing steel, through hardened races and rollers
- Cast steel housing
- Lifetime warranty against breakage on the housings (Standard Terms & Conditions apply)
- Easy field conversion from fixed to floating
- Bore sizes from 1-7/16" through 4-15/16"
- Includes grease fitting and grease purge ports



# Hub City ModuLine® Spherical Roller Bearing Units

## Features - Seals and Covers

### Double Lip Nitrile Seal

- Non-purging, Recommended for heavy moisture and gritty materials.
- Not recommended for most chemical contaminants.
- Typical applications include ground contact equipment, agricultural machinery, etc.

### Triple Lip Nitrile Seal

- Purgeable, good for large particulate contamination, and moisture.
- Not recommended for most chemical contaminants.
- Typical applications include sawmills, forestry equipment etc.

### Labyrinth Teflon Seal

- Labyrinth Teflon seals are non-purging, and low drag.
- Suitable for all speeds, high temperature, and moisture.
- PTFE (Teflon) is non-reactive to most chemicals.
- Labyrinth Teflon seals are recommended for most industrial applications.

### Covers

#### Closed Covers

- Closed covers are designed to completely seal the exposed end of a rotating shaft. These heavy duty metal covers fasten to the bearing lock ring and the entire cavity can be filled with grease, effectively limiting fretting corrosion between bearing bore and shaft.

#### Open Covers

- Open covers allow the shaft to pass through the cover while providing an auxiliary labyrinth Teflon seal on the shaft. These heavy duty metal covers fasten to the bearing lock ring and the entire cavity can be filled with grease, effectively limiting fretting corrosion between bearing bore and shaft.

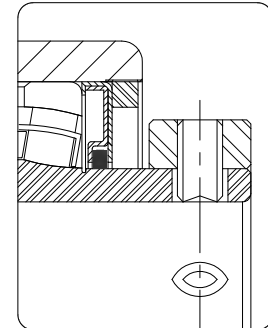
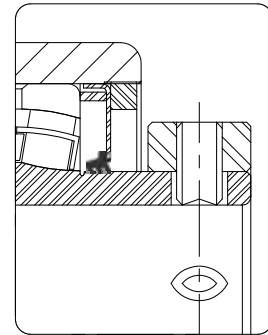
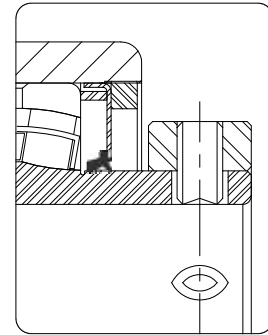

# Hub City ModuLine® Spherical Roller Bearing Units

## Engineering and Selection Information

### Maximum Speed

Maximum speed limits listed for the ModuLine® Spherical Roller Bearing units described in this catalog should be used as a guide and considered along with other factors affecting bearing operation. Load characteristics, bearing lubrication, and temperature factors all influence bearing operation. It is possible that cataloged speed limits may be exceeded after a complete application analysis is completed by factory engineers.

### Bearing Life

Bearing life is commonly referred to in terms of the number of hours of operation, at a given load and speed that 90% of the bearings in a lot can equal or exceed before the onset of fatigue failure. This is called the L-10 life of a bearing.

### Bearing Loads

Radial loads and axial (thrust) forces in combination are the principal load components of bearing applied loads. Hub City bearing unit ratings are based upon the radial load capacity of the bearing. Spherical roller bearings are designed to handle significant radial loads even when combined with a thrust load. However, these bearings are not generally recommended for use in applications where only thrust forces are present or when thrust loads exceed the radial loading of the bearing.

The charts on page P4 and P-7 are to be used when only radial loads are present, or once the combined equivalent load value is calculated. For applications where bearings are required to absorb thrust forces in addition to normal radial loads, the following considerations must be made concerning the magnitude of the thrust force.

1. When thrust loads are less than 25% of the radial load the equivalent load is determined by adding the radial and thrust loads together. The bearing selection is based upon using this total load as the equivalent applied radial load.
2. When thrust loads are equal to or greater than 25% of the radial load – the application must be reviewed by the factory.

Table 1: Basic Radial loads

Shaft Size (in)	Dynamic Load $C_r$ Capacity (Lb.)	Static Load $C_{Or}$ Capacity (Lb.)
1-7/16 1-1/2	20200	22500
1-11/16 1-3/4	21150	24320
1-15/16 2	22500	27150
2-3/16 2-1/4	27300	31940
2-7/16 2-1/2	39800	48600
2-11/16 2-3/4 2-15/16 3	43020	53980
3-7/16 3-1/2	68550	87700
3-15/16 4	85500	108980
4-7/16	108000	144050
4-15/16	124500	186250

### Bearing Selection

Selection of the proper Hub City bearing unit for a determined speed and load can be made by referring to the load rating tables. Proper selection is made by finding a bearing having the desired bore size which has a load rating equal to or greater than the radial or equivalent radial load required for the application.

### Engineering Data

Bearing reaction loads are caused by forces acting on the shaft supported by the bearings. These forces are a result of the weight of the shafting and components mounted on the shafting, bending loads due to belt or chain pull, gear reaction loads, and off center or unbalanced loads. These loads must be combined into a single resultant load of known magnitude and direction for each bearing. Whether the load is applied between bearings on a shaft supported by two bearings or outboard of one of the bearings is important to proper bearing selection. The magnitude and direction of the load for either case may be calculated by taking moments about the other bearing.

# Hub City ModuLine® Spherical Roller Bearing Units

## Engineering and Selection Information

### Minimum Loads

Although it may be a rare application where little or no loads are present, spherical roller bearings must have proper loads present in the application in order to function satisfactorily. Radial loads less than 3% of Cr (see page P-4) should be avoided.

### Misalignment

All Hub City ModuLine® Spherical Roller Bearing units can accept up to 1-1/2 degrees misalignment.

### Lubrication

The proper lubrication of bearing units is critical in order to attain maximum bearing life expectancy. HUB CITY SPHERICAL ROLLER BEARINGS are factory filled with Ulti-Plex® Synthetic EP Grease, which is a multipurpose, high performance grease specially formulated for extreme pressure bearing applications operating under the most extreme high and low temperature conditions and for those difficult applications requiring extended lubrication intervals. This grease offers excellent thermal stability through temperatures ranging from -50° F to 400° F (-50° to 230° C). When dealing with temperatures above 300° F, consult the factory for optional grease recommendations. All Hub City bearing units are lubricated at the factory and should not require additional lubricant upon installation. Re-lubrication intervals noted in Table 3 are to be used as a general guide and depend on the type of application, speed, operating temperature and other environmental conditions. The amount and

type of lubricant used will affect bearing life. Improper lubrication can lead to premature bearing failures. For unusual lubrication requirements or severe duty applications, contact Hub City for recommendations.

Seal Limiting Speeds (RPM)

Shaft Size (in)	Nitrile Contact Seal	Labyrinth Seal
1-7/16 1-1/2	2000	4000
1-11/16 1-3/4	2000	4000
1-15/16 2	1800	3600
2-3/16 2-1/4	1600	3200
2-7/16 2-1/2	1200	2800
2-11/16 2-3/4 2-15/16 3	1200	2400
3-7/16 3-1/2	1000	2000
3-15/16 4	900	1600
4-7/16	700	1200
4-15/16	500	1000

### Ordering information – Example

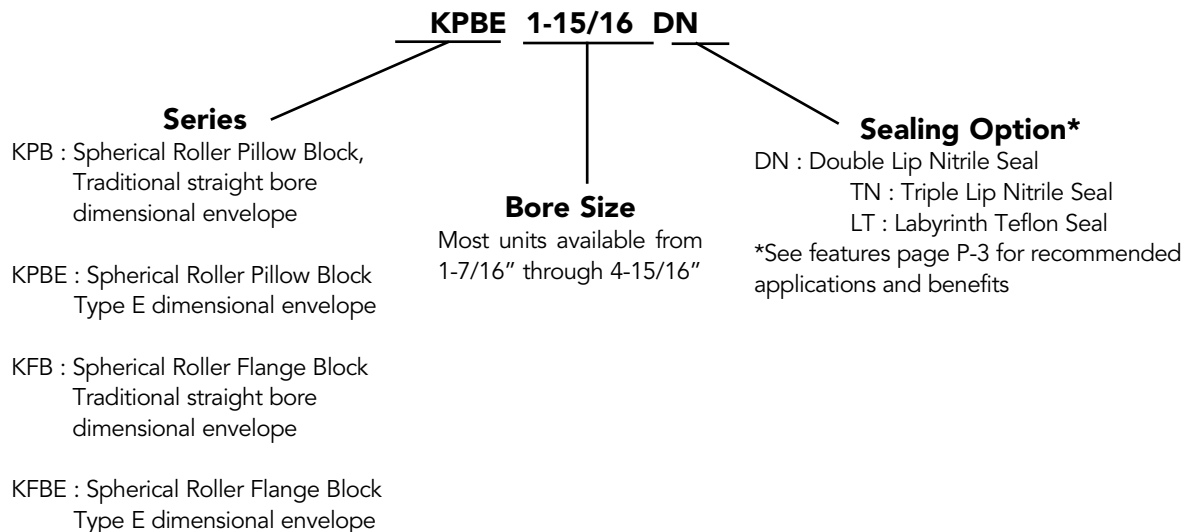

# Hub City ModuLine® Spherical Roller Bearing Units

## Engineering and Selection Information

### Procedure to Convert Spherical Roller Bearing from Fixed to Floating (Non-Expansion to Expansion)

#### FLANGE BLOCK HOUSING

1. Make a reference mark on the housing and retaining nut.
2. Loosen set screws in housing that lock the retaining nut in place.
3. Loosen retaining nut by tapping with a hammer and punch, rotating retaining nut counter clockwise one complete revolution.
4. Tighten set screws in housing to lock retaining nut in place.

Please note: When converting a Spherical Roller bearing from fixed to floating, please ensure that the bearing is correctly oriented. A bearing that has been converted to expansion can only float in the direction of the loosened retaining nut.

#### PILLOW BLOCK HOUSING

1. Determine amount and direction of expansion needed. If uni-directional expansion is required, follow above directions on the nut that is on the side where expansion is desired
2. If bi-directional expansion is required follow the directions above on both nuts but the rotation should be one-half a revolution on each nut instead of one complete revolution.

### Procedure to Convert Spherical Roller Bearing from Floating to Fixed (Expansion to Non-Expansion)

#### FLANGE BLOCK HOUSING

1. Loosen set screws in housing that lock the retaining nut in place.
2. Tighten retaining nut by tapping with a hammer and punch, rotating retaining nut clockwise until tight. It is not possible to over-tighten the retaining nut.
3. Tighten set screw in housing to lock retaining nut in place.

#### PILLOW BLOCK HOUSING

1. Follow directions above on both nuts on either side of the housing.

Please Note: When converting from floating to fixed on a bearing that is mounted in the application, the set screws on the collars must be loosened to allow the insert to move in the housing and on the shaft.

# Hub City ModuLine® Spherical Roller Bearing Units

## Load Ratings

### Radial and Equivalent Load Ratings By Operating Speed

Shaft Size (in)	Life Hrs	Operating Speed (RPM)										
		50	100	200	500	1000	1200	1500	1800	2400	3000	3500
1-7/16 1-1/2	5000	8997	7257	5906	4487	3648	3478	3260	3079	2833	2637	2515
	10000	7308	5894	4798	3644	2963	2825	2647	2501	2301	2141	2043
	20000	5936	4788	3896	2960	2407	2294	2150	2032	1870	1739	1659
	50000	4509	3637	2960	2248	1828	1743	1633	1544	1420	1322	1261
	100000	3662	2954	2405	1827	1485	1416	1327	1253	1153	1073	1024
1-11/16 1-3/4	5000	9398	7580	6169	4686	3810	3633	3405	3217	2959	2754	2627
	10000	7633	6157	5011	3807	3095	2951	2765	2613	2404	2237	2134
	20000	6200	5001	4070	3092	2514	2397	2246	2123	1952	1817	1733
	50000	4709	3799	3092	2349	1909	1821	1706	1612	1484	1380	1317
	100000	3826	3085	2511	1907	1551	1479	1386	1310	1205	1121	1069
1-15/16 2	5000	9996	8062	6562	4985	4053	3864	3621	3422	3148	2930	2795
	10000	8119	6549	5330	4049	3292	3139	2941	2779	2557	2380	2270
	20000	6595	5319	4329	3289	2674	2550	2390	2257	2077	1933	1844
	50000	5010	4041	3289	2498	2031	1937	1815	1715	1578	1468	1401
	100000	4069	3283	2671	2029	1650	1573	1474	1393	1281	1193	1137
2-3/16 2-1/4	5000	12131	9785	7963	6050	4918	4689	4395	4153	3820	3556	3391
	10000	9854	7947	6469	4913	3995	3809	3570	3373	3103	2888	2754
	20000	8003	6456	5254	3991	3245	3093	2899	2740	2521	2346	2237
	50000	6080	4903	3991	3032	2465	2351	2202	2081	1915	1782	1699
	100000	4938	3983	3242	2463	2002	1910	1789	1690	1555	1447	1381
2-7/16 2-1/2	5000	17693	14271	11615	8823	7175	6840	6410	6056	5572	5187	
	10000	14372	11592	9435	7167	5827	5556	5206	4919	4526	4212	
	20000	11673	9416	7663	5821	4734	4512	4228	3996	3676	3421	
	50000	8868	7153	5821	4423	3596	3428	3212	3035	2793	2599	
	100000	7203	5810	4729	3592	2920	2785	2609	2465	2268	2111	
2-11/16 2-3/4 2-15/16 3	5000	19094	15401	12534	9522	7742	7382	6917	6536	6014		
	10000	15509	12509	10181	7735	6288	5996	5618	5308	4885		
	20000	12597	10161	8270	6282	5108	4890	4564	4312	3967		
	50000	9570	7719	6282	4773	3880	3699	3467	3275	3014		
	100000	7774	6269	5103	3876	3152	3005	2816	2661	2448		
3-7/16 3-1/2	5000	30492	24593	20017	15205	12363	11788	11046	10437	9603		
	10000	24766	19977	16258	12351	10042	9575	8972	8477	7800		
	20000	20117	16225	13206	10032	8157	7777	7288	6886	6335		
	50000	15282	12326	10032	7621	6197	5907	5536	5231	4813		
	100000	12413	10012	8148	6190	5033	4799	4496	4249	3909		
3-15/16 4	5000	37989	30641	24938	18944	15403	14685	13762	13004			
	10000	30857	24888	20256	15388	12511	11928	11178	10563			
	20000	25064	20215	16452	12498	10163	9689	9079	8580			
	50000	19039	15357	12498	9494	7720	7361	6897	6517			
	100000	15465	12473	10152	7712	6270	5979	5602	5293			
4-7/16	5000	47981	38700	31497	23927	19454	18548	17382	16424			
	10000	38972	31434	25584	19435	15802	15066	14118	13340			
	20000	31655	25533	20780	15786	12835	12237	11468	10836			
	50000	24047	19396	15786	11992	9750	9296	8712	8231			
	100000	19532	15755	12822	9741	7920	7551	7076	6686			
4-15/16	5000	55228	44546	36256	27542	22393	21350	20007				
	10000	44860	36183	29448	22371	18189	17341	16251				
	20000	36438	29389	23920	18170	14774	14086	13200				
	50000	27680	22326	18170	13803	11224	10700	10028				
	100000	22483	18134	14760	11212	9116	8691	8145				

These ratings are published as a guide only. Actual bearing life can be influenced by many factors including contamination, speed, loading, vibration etc. For help in determining actual application life, please consult factory."

# Hub City ModuLine® Spherical Roller Bearing Units

## Chemical Compatibility of Seal Materials

A - Little to no effect

B - Minor to moderate effect

C - Severe effect to destruction

N - No data. Test prior to use

Chemical	Urethane	Nitrile	Viton	Teflon
Acetaldehyde	C	C	C	A
Acetamide	N	A	B	A
Acetic Acid	C	B	B	A
Acetic Anhydride	C	C	C	A
Acetone	C	C	C	A
Acetyl Bromide	C	N	N	N
Acetyl Chloride	C	C	A	A
Acetylene	C	A	A	A
Adipic Acid	A	A	N	A
Aeor Shell Grease	B	A-B	A	A
Aero Lubriplate	A	A	A	A
Aero Safe 2300	N	C	C	A
Aerozene 50	N	C	C	A
Aluminum Acetate	N	A	C	A
Aluminum Bromide	N	A	A	A
Aluminum Chloride	B	A	A	A
Aluminum Sulfate	B	A	A	A
Ammonia	B	B	C	A
Ammonium Carbonate	B	C	N	A
Ammonium Chloride	N	A	A	A
Ammonium Hydroxide	B	C	A	A
Ammonium Nitrate	B	A	N	A
Ammonium Persulfate	B	C	N	A
Ammonium Sulfate	B	A	C	A
Ammonium Sulfide	B	A	C	A
Ammonium Thiocyanate	B	N	N	A
Ammonium Acetate	C	N	N	A
Amyl Acetate	C	C	C	A
Amyl Alcohol	C	B	C	A
Aniline	C	C	C	A
Aniline Hydrochloride	C	B	B	B
Animal Fats & Oils	B	A	A	A
Antimony Salts	B	N	N	A
Aqua Regia	C	C	B	A
Arsenic Salts	B	N	N	A
ASTM Oil #1	A	A	A	A
ASTM Oil #2	B	A	A	A
ASTM Oil #3	B	A	A	A
ASTM Reference Fuel	A	A	A	A
ASTM Reference Fuel	B	B	A	A
Atlantic Oil	A	A	A	A
Barium Carbonate	B	A	A	A
Barium Hydroxide	A	A	A	A
Beer	A	A	A	A
Benzaldehyde	B	C	C	A
Benzene	C	C	B	A
Benzoic Acid	B	C	A	A
Black Sulphate Liquors	N	B	A	A
Bleach Solutions	N	C	A	B

A - Little to no effect

B - Minor to moderate effect

C - Severe effect to destruction

N - No data. Test prior to use

Chemical	Urethane	Nitrile	Viton	Teflon
Boric Acid	A	A	A	A
Brake Fluid	N	C	C	N
Bromine	B	C	A	C
Bunker Oil	A	A	A	A
Butane	A	A	A	A
Butyl Acetate	C	C	C	A
Butyl Alcohol	B	A	A	A
Calcium Carbonate	B	A	A	A
Calcium Chloride	A	A	A	A
Calcium Hydroxide	A	A	A	A
Calcium Nitrate	B	A	A	A
Calcium Sulfate	B	B	B	A
Carbon Dioxide	A	A	A	A
Carbon Disulfide	B	C	A	A
Carbon Monoxide	A	A	A	A
Carbon Tetrachloride	C	C	A	A
Chlorine	N	C	A	B
Chloroacetic Acid	C	C	C	N
Chloroform	C	N	N	B
Chromic Acid	C	C	A	B
Chromium Potassium Sulfate	A	N	N	N
Citric Acid	B	A	A	A
Corn Oil	A	A	A	A
Cottonseed Oil	A	A	A	A
Cresol	C	C	A	A
Crude Oil	B	B	A	A
Cupric Chloride	A	B	B	A
Cupric Nitrate	B	N	N	A
Cupric Sulfate	B	B	B	A
Cutting Oil	B	A	A	A
Cyclohexane	B	A	A	A
Cyclohexanone	C	C	A	A
Dibutyl Phthalate	C	C	C	B
Dichlorobenzene	C	N	N	B
Diesel Fuel	B	A	A	A
Diester Oil	B	B	A	A
Dimethyl Acetamide	C	N	N	A
Dimethyl Formamide	C	B	C	A
Dodecyl Mercaptan	B	N	N	N
DTE Oil	B	A	N	N
Dubutyl Ether	B	C	C	N
EP Lubes	A	A	A	A
Esso #90 Lube Oil	A	A	A	A
Ether	B	N	N	A
Ethyl Acetate	C	C	C	A
Ethyl Alcohol (Ethanol)	C	A	C	A
Formic Acid	C	B	C	A
Freon, 12 or 113	A	A	B	A
Fuel Oil	B	A	A	A



# Hub City ModuLine® Spherical Roller Bearing Units

## Chemical Compatibility of Seal Materials

A - Little to no effect B - Minor to moderate effect C - Severe effect to destruction N - No data. Test prior to use				
Chemical	Urethane	Nitrile	Viton	Teflon
Gasoline	B	B	A	A
Glucose	A	A	A	A
Glue	N	A	A	A
Glycerin	A	A	A	A
Heptane	A	N	N	A
Hexane	A	A	A	A
Hydrazine	C	B	C	B
Hydrobromic Acid	B	C	A	A
Hydrocarbon Oil	A	A	A	A
Hydrochloric Acid	B	C	B	A
Hydrofluoric Acid	B	C	C	A
Hydrogen	A	A	A	A
Hydrogen Peroxide	B	C	A	B
Hydrogen Sulfide	C	C	C	A
Hydrologic Acid	B	N	N	N
Iodine	A	B	A	A
Isobutyl Alcohol	N	B	A	A
Isopropyl Chloride	N	C	A	A
Isopropyl Ether	B	B	C	N
Isopropyl Alcohol (Propanol)	B	A	A	N
JP4 Oil	B	A	A	A
JP5 & 6 Oil	C	A	A	A
Kerosene	B	A	A	A
Lactic Acid	B	B	A	A
Lead Acetate	B	B	C	A
Linseed Oil	B	A	A	A
Liquefied Petroleum Gas	A	A	A	N
Lubrication Oil	B	A	A	A
Lye	N	B	B	A
Magnesium Chloride	N	A	A	A
Magnesium Hydroxide	A	B	A	A
Magnesium Salts	B	A	A	A
Malaic Acid	C	C	A	A
Mercury	B	A	A	A
Methyl Alcohol (methanol)	A	C	A	N
Methyl Ethyl Ketone	C	C	C	A
Methylene Chloride	C	C	B	A
MIL-D-5606 Oil	C	A	A	A
MIL-L7808 Oil	B	B	A	A
Mineral Oil	A	A	A	A
Mineral Spirits	N	B	A	A
Naphthalene	B	C	A	A
Natural Gas	B	A	A	A
Nickel Salts	C	A	A	A
Oxygen	A	B	A	A
Ozone	A	C	A	A
Paimitic Acid	A	A	A	A
Paint Thinner	B	C	B	A
Peanut Oil	A	A	A	A

A - Little to no effect B - Minor to moderate effect C - Severe effect to destruction N - No data. Test prior to use				
Chemical	Urethane	Nitrile	Viton	Teflon
Perchloric Acid	C	C	A	A
Perchloroethylene	C	B	A	A
Petroleum	B	A	A	A
Phenol (carbolic acid)	C	C	A	A
Phosphoric Acid	C	C	A	A
Potassium Cyanide	A	A	A	A
Potassium Salts	B	A	A	A
Propane	B	A	A	A
Propyl Alcohol	B	A	A	A
Propylene Glycol	B	N	N	A
Pydraul Oil	C	C	A	A
SAE #10 Oil	A	A	A	A
Seawater	A	A	A	A
Silicic Acid	B	N	N	A
Silver Nitrate	B	B	A	A
Skydrol Oil	C	C	C	A
Soap	B	A	A	A
Sodium Acetate	A	B	C	A
Sodium Bicarbonate	B	A	A	A
Sodium Borate	B	A	A	A
Sodium Carbonate	B	A	A	A
Sodium Chloride	B	A	A	A
Sodium Cyanide	B	A	A	A
Sodium Hydrosulfite	B	N	N	A
Sodium Hydroxide	B	B	B	A
Sodium Hypochlorite	C	B	A	A
Sodium Nitrate	B	B	N	A
Sodium Silicate	A	A	A	A
Sodium Sulfate	B	A	A	A
Sodium Sulfide	B	A	A	A
Steam	C	C	C	A
Styrene	B	C	B	A
Sulfur Dioxide	B	C	A	A
Sulfuric Acid	C	C	A	A
Tannic Acid	A	A	A	A
Tartaric Acid	A	A	A	A
Toluene	C	N	N	A
Transformer Oil	B	N	N	A
Turpentine	C	A	A	A
Urea	B	N	N	A
Varnish	B	B	A	A
Water	B	A	A	A

# Hub City ModuLine® Spherical Roller Bearing Units

## Traditional Straight Bore Dimensions - Model KPB

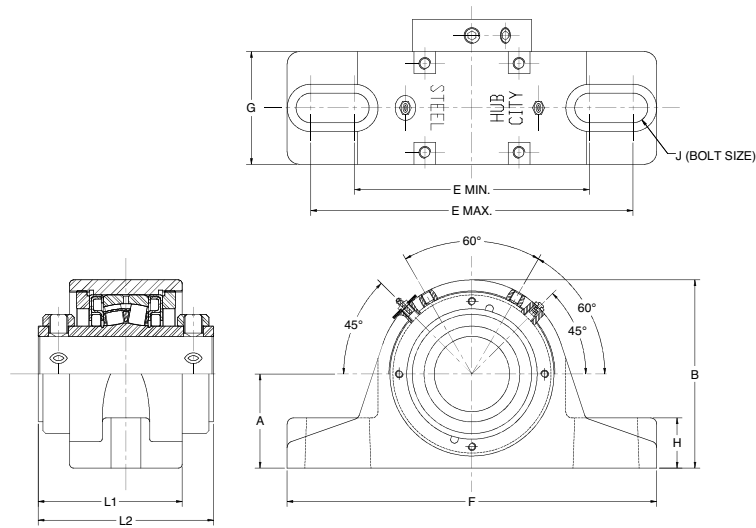

Note: Dimensions  $\frac{\text{in}}$   
Shown are:  $\frac{\text{mm}}$

Bearing bore size tolerances are as follows:  
1.4375 to 2.500 +.001/-0  
2.6875 to 4.9375 +.0015/-0

Note: Shaft sizes 2-15/16" and up have a dual locking collar, L2 dimension applies.

### Two Bolt Pillow Blocks

DESCRIPTION	BORE SIZE	SET-SCREW	A	B	E (MIN)	E (MAX)	F	G	H	J (BOLT SIZE)	L1	L2	WEIGHT (LBS.)
KPB1-7/16*	1.438	3/8-24 UNF	1.875	3.75	4.69	5.31	6.87	2.24	1.00	1/2	2.87		12
KPB1-1/2L*	1.500		[47.63]	[95.3]	[119.0]	[134.9]	[174.6]	[57.0]	[25.4]		[73.0]		
KPB1-11/16*	1.688	3/8-24 UNF	2.125	4.13	5.25	5.81	7.13	2.24	1.00	1/2	3.00		14
KPB1-3/4*	1.750		[53.98]	[105.0]	[133.4]	[147.6]	[181.0]	[57.0]	[25.4]		[76.1]		
KPB1-15/16*	1.938	3/8-24 UNF	2.250	4.50	5.94	6.56	8.13	2.24	1.22	5/8	3.00		14
KPB2*	2.000		[57.15]	[114.3]	[150.8]	[166.7]	[206.4]	[57.0]	[31.0]		[76.1]		
KPB2-3/16*	2.188	3/8-24 UNF	2.500	5.00	6.50	7.06	8.87	2.36	1.22	5/8	3.18		18
KPB2-1/4*	2.250		[63.50]	[127.0]	[165.1]	[179.4]	[225.4]	[60.0]	[31.0]		[80.8]		
KPB2-7/16*	2.438	1/2-20 UNF	2.750	5.50	6.81	7.44	9.25	2.80	1.38	5/8	3.52		23
KPB2-1/2*	2.500		[69.85]	[139.7]	[173.0]	[188.9]	[235.0]	[71.0]	[35.0]		[89.5]		
KPB2-11/16*	2.688	1/2-20 UNF	3.250	6.37	7.72	8.43	10.44	2.92	1.38	3/4	3.84		30
KPB2-3/4*	2.750										[97.4]		
KPB2-15/16*	2.938											4.75	
KPB3*	3.000										[120.7]		
KPB3-7/16*	3.438	1/2-20 UNF	3.750	7.50	9.25	10.75	13.00	3.50	1.85	7/8		5.19	45
KPB3-1/2*	3.500		[95.25]	[190.5]	[235.0]	[273.0]	[330.2]	[88.9]	[47.0]		[131.7]		
KPB3-15/16*	3.938	5/8-18 UNF	4.250	8.50	10.00	12.88	15.25	3.74	2.00	1		5.94	60
KPB4*	4.000		[107.95]	[215.9]	[254.0]	[327.2]	[387.4]	[95.0]	[50.8]		[150.8]		

\* Specify Seal Design and Material  
LT: Labyrinth Teflon (std)  
DN: Double Lip Nitrile  
TN: Triple Lip Nitrile  
See pages P-3 and P-5 for more information

DOWNLOAD AVAILABLE CAD MODELS AT: [WWW.HUBCITYINC.COM](http://WWW.HUBCITYINC.COM)

Certified prints are available upon request

CALL: (605) 225-0360 • FAX: (605) 225-0567

# Hub City ModuLine® Spherical Roller Bearing Units

## Traditional Straight Bore Dimensions - Model KPBF

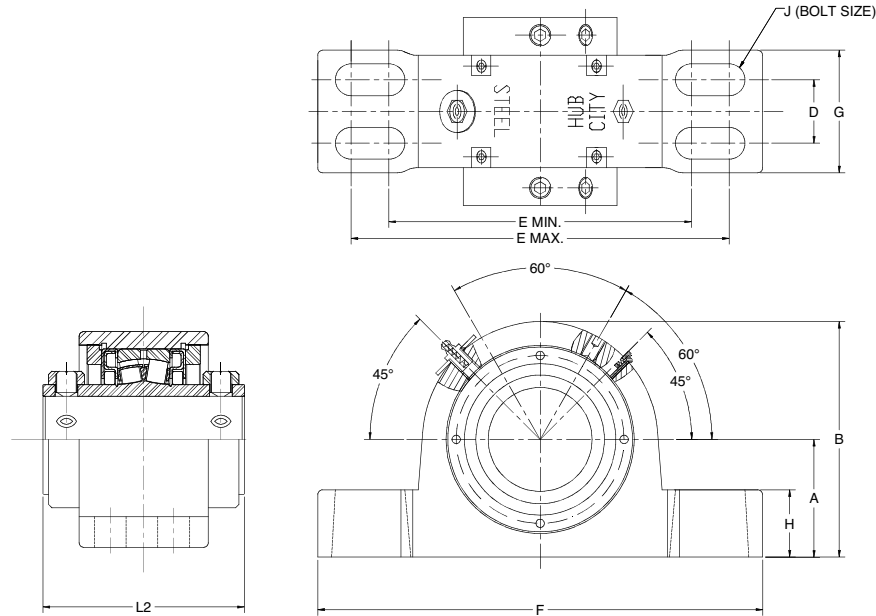

Note: Dimensions  $\frac{\text{in}}$   
Shown are:  $\text{mm}$

Bearing bore size tolerances are as follows:  
1.4375 to 2.500 +.001/-0  
2.6875 to 4.9375 +.0015/-0

### Four Bolt Pillow Blocks

DESCRIPTION	BORE SIZE	SET-SCREW	A	B	D	E (MIN)	E (MAX)	F	G	H	J (BOLT SIZE)	L2	WEIGHT (LBS.)
KPBF3-7/16*	3.438	1/2-20 UNF	3.750 [95.25]	7.50 [190.5]	1.97 [50.0]	8.88 [225.5]	10.88 [276.3]	12.30 [312.4]	3.74 [95.0]	1.85 [47.0]	3/4	5.19 [131.7]	45
KPBF3-15/16*	3.938	5/8-18 UNF	4.250 [107.95]	8.50 [215.9]	2.25 [57.1]	10.88 [276.3]	13.39 [340.0]	14.88 [378.0]	4.33 [110.0]	2.00 [50.8]	3/4	5.94 [150.8]	60
KPBF4-7/16*	4.438	5/8-18 UNF	4.750 [120.65]	9.70 [246.4]	2.50 [63.5]	13.00 [330.2]	14.00 [355.6]	15.88 [403.3]	4.72 [120.0]	2.00 [50.8]	3/4	6.13 [155.6]	90
KPBF4-15/16*	4.938	5/8-18 UNF	5.500 [139.70]	10.98 [279.0]	2.76 [70.0]	15.00 [381.0]	16.00 [406.4]	18.63 [473.1]	5.12 [130.0]	2.00 [50.8]	7/8	6.63 [168.3]	90

\* Specify Seal Design and Material

LT: Labyrinth Teflon (std)

DN: Double Lip Nitrile

TN: Triple Lip Nitrile

See pages P-3 and P-5 for more information

# Hub City ModuLine® Spherical Roller Bearing Units

## Traditional Straight Bore Dimensions - Model KFB

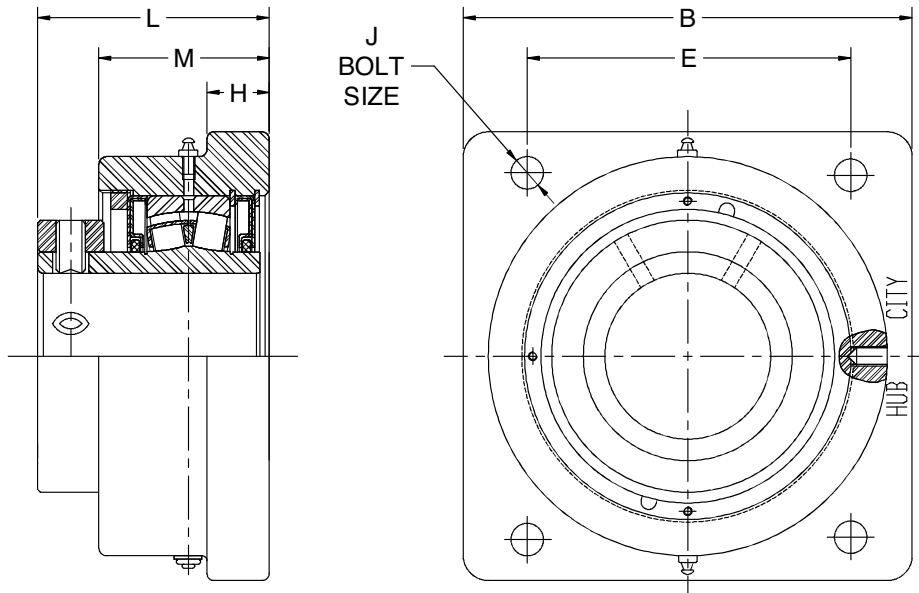

Bearing bore size tolerances are as follows:  
 1.4375 to 2.500 +.001/-0  
 2.6875 to 4.9375 +.0015/-0

Note: Dimensions  $\frac{\text{in}}$   
 Shown are:  $\frac{\text{mm}}$

### Four Bolt Flange Blocks

DESCRIPTION	BORE SIZE	SETSCREW	B	E	H	J (BOLT SIZE)	L	M	WEIGHT (LBS.)
KFB1-7/16*	1.438	3/8-24 UNF	4.63	3.53	0.63	1/2	2.87	2.13	10
KFB1-1/2*	1.500		[117.5]	[89.7]	[16.0]		[73.0]	[54.0]	
KFB1-11/16*	1.688	3/8-24 UNF	5.37	3.89	0.63	1/2	2.99	2.20	10
KFB1-3/4*	1.750		[136.5]	[98.8]	[16.0]		[76.0]	[56.0]	
KFB1-15/16*	1.938	3/8-24 UNF	5.19	4.06	0.63	1/2	2.99	2.20	12
KFB2*	2.000		[131.8]	[103.2]	[16.0]		[76.0]	[56.0]	
KFB2-3/16*	2.188	3/8-24 UNF	5.87	4.50	0.79	5/8	3.24	2.44	14
KFB2-1/4*	2.250		[149.2]	[114.3]	[20.0]		[82.4]	[62.0]	
KFB2-7/16*	2.438	1/2-20 UNF	6.19	4.76	0.87	5/8	3.49	2.72	18
KFB2-1/2*	2.500		[157.2]	[121.0]	[22.0]		[88.7]	[69.0]	
KFB2-11/16*	2.688	1/2-20 UNF	7.19	5.56	0.87	3/4	3.74	2.72	24
KFB2-3/4*	2.750								
KFB2-15/16*	2.938								
KFB3*	3.000								
KFB3-7/16*	3.438	1/2-20 UNF	8.37	6.72	0.94	3/4	4.15	3.11	35
KFB3-1/2*	3.500		[212.7]	[170.7]	[24.0]		[105.4]	[79.0]	
KFB3-15/16*	3.938	5/8-18 UNF	9.50	7.59	1.10	1	4.71	3.50	55
KFB4*	4.000		[241.3]	[192.9]	[28.0]		[119.7]	[89.0]	

\* Specify Seal Design and Material  
 LT: Labyrinth Teflon (std)  
 DN: Double Lip Nitrile  
 TN: Triple Lip Nitrile  
 See pages P-3 and P-5 for more information

DOWNLOAD AVAILABLE CAD MODELS AT: [WWW.HUBCITYINC.COM](http://WWW.HUBCITYINC.COM)

**Certified prints are available upon request**

CALL: (605) 225-0360 • FAX: (605) 225-0567

# Hub City ModuLine® Spherical Roller Bearing Units

## Type E Dimensions - Model KPBE

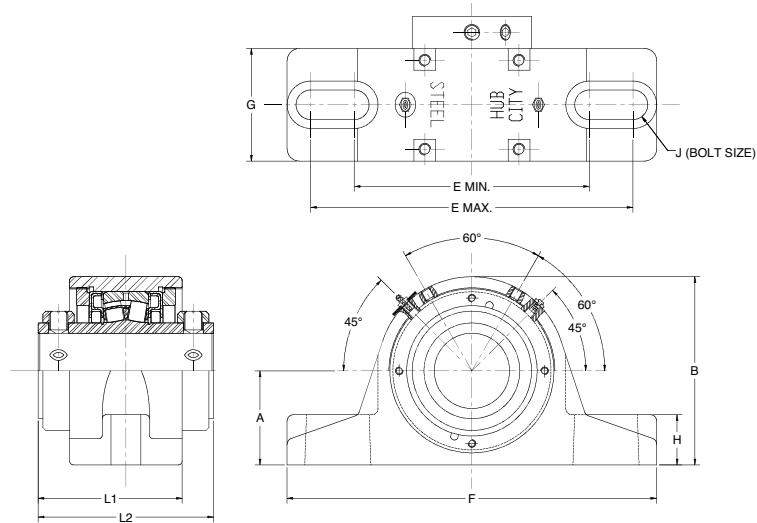

Note: Dimensions  $\frac{\text{in}}$   
Shown are:  $\frac{\text{mm}}$

Note: Shaft sizes 2-15/16" and up have a dual locking collar, L2 dimension applies.

Bearing bore size tolerances are as follows:  
1.4375 to 2.500 +.001/-0  
2.6875 to 4.9375 +.0015/-0

### Two Bolt Pillow Blocks

DESCRIPTION	BORE SIZE	SETSCREW	A	B	E (MIN)	E (MAX)	F	G	H	J (BOLT SIZE)	L1	L2	WEIGHT (LBS.)									
KPBE1-7/16*	1.438	3/8-24 UNF	1.875	3.75	4.69	6.00	7.36	2.24	1.00	1/2	2.87		12									
KPBE1-1/2*	1.500		[47.63]	[95.3]	[119.0]	[152.4]	[187.0]	[57.0]	[25.4]		[73.0]											
KPBE1-11/16*	1.688	3/8-24 UNF	2.125	4.13	5.69	6.50	7.87	2.24	1.00	1/2	3.00		14									
KPBE1-3/4* Δ	1.750		[53.98]	[105.0]	[144.5]	[165.1]	[200.0]	[57.0]	[25.4]		[76.1]											
KPBE1-15/16*	1.938	3/8-24 UNF	2.250	4.50	6.00	7.25	8.86	2.24	1.22	5/8	3.00		14									
KPBE2*	2.000		[57.15]	[114.3]	[152.4]	[184.2]	[225.0]	[57.0]	[31.0]		[76.1]											
KPBE2-3/16*	2.188	3/8-24 UNF	2.500	5.00	6.50	8.00	9.63	2.36	1.22	5/8	3.18		18									
KPBE2-1/4* Δ	2.250		[63.50]	[127.0]	[165.1]	[203.2]	[244.5]	[60.0]	[31.0]		[80.8]											
KPBE2-7/16*	2.438	1/2-20 UNF	2.750	5.50	6.88	8.74	10.24	2.80	1.38	5/8	3.52		23									
KPBE2-1/2*	2.500		[69.85]	[139.7]	[174.8]	[222.0]	[260.0]	[71.0]	[35.0]		[89.5]											
KPBE2-11/16*	2.688	1/2-20 UNF	3.125	6.25	7.88	9.76	11.75	2.92	1.38	3/4	3.84		30									
KPBE2-3/4*	2.750										[79.38]	[158.8]		[200.2]	[248.0]	[298.5]	[74.2]	[35.0]	[97.4]			
KPBE2-15/16*	2.938																				4.75	
KPBE3* Δ	3.000																				[120.7]	
KPBE3-7/16*	3.438	1/2-20 UNF	3.75	7.50	9.38	11.50	13.74	3.50	1.85	7/8		5.19	45									
KPBE3-1/2*	3.500		[95.3]	[190.5]	[238.3]	[292.1]	[349.0]	[88.9]	[47.0]		[131.7]											
KPBE3-15/16*	3.938	5/8-18 UNF	4.13	8.30	10.04	12.63	14.50	3.74	2.00	1		5.94	60									
KPBE4*	4.000		[104.8]	[210.8]	[255.0]	[320.8]	[368.3]	[95.0]	[50.8]		[150.8]											

\* Specify Seal Design and Material  
 LT: Labyrinth Teflon (std)  
 DN: Double Lip Nitrile  
 TN: Triple Lip Nitrile  
 See pages P-3 and P-5 for more information

Δ Note: Confirm all critical mounting dimensions. Shimming and/or housing modifications may be required when interchanging with mounted tapered roller units.

# Hub City ModuLine® Spherical Roller Bearing Units

## Type E Dimensions - Model KPBE

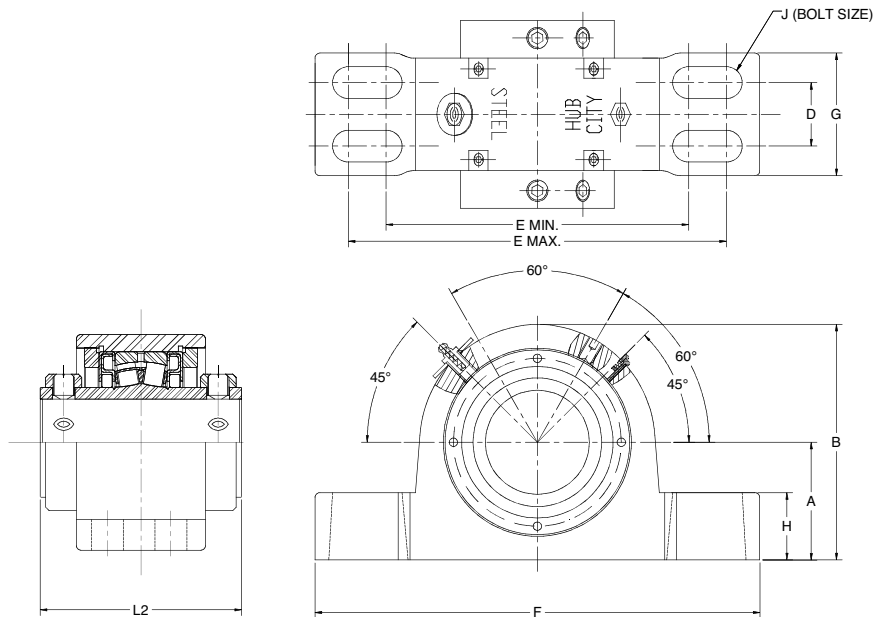

Note: Dimensions  $\frac{\text{in}}$   
Shown are:  $\frac{\text{mm}}$

Bearing bore size tolerances are as follows:  
1.4375 to 2.500 +.001/-0  
2.6875 to 4.9375 +.0015/-0

### Four Bolt Pillow Blocks

DESCRIPTION	BORE SIZE	SETSCREW	A	B	D	E (MIN)	E (MAX)	F	G	H	J (BOLT SIZE)	L2	WEIGHT (LBS.)
KPBEF3-7/16*	3.438	1/2-20 UNF	3.750 [95.25]	7.50 [190.5]	2.38 [60.5]	9.25 [235.0]	11.25 [285.7]	13.63 [346.2]	4.13 [105.0]	1.85 [47.0]	3/4	5.19 [131.7]	45
KPBEF3-15/16*	3.938	SEE KPBF3-15/16 (PAGE 11)										60	
KPBEF4-7/16*	4.438	5/8-18 UNF	4.750 [120.65]	9.70 [246.4]	2.50 [63.5]	11.83 [300.4]	14.50 [368.3]	16.13 [409.6]	4.72 [120.0]	2.00 [50.8]	3/4	6.13 [155.6]	90
KPBEF4-15/16*	4.938	5/8-18 UNF	5.500 [139.70]	10.98 [279.0]	2.76 [70.0]	15.13 [384.3]	15.88 [403.4]	17.50 [444.5]	5.12 [130.0]	2.00 [50.8]	7/8	6.63 [168.3]	90

\* Specify Seal Design and Material  
LT: Labyrinth Teflon (std)  
DN: Double Lip Nitrile  
TN: Triple Lip Nitrile  
See pages P-3 and P-5 for more information

DOWNLOAD AVAILABLE CAD MODELS AT: [WWW.HUBCITYINC.COM](http://WWW.HUBCITYINC.COM)

**Certified prints are available upon request**

CALL: (605) 225-0360 • FAX: (605) 225-0567

# Hub City ModuLine® Spherical Roller Bearing Units

## Type E Dimensions - Model KFBE

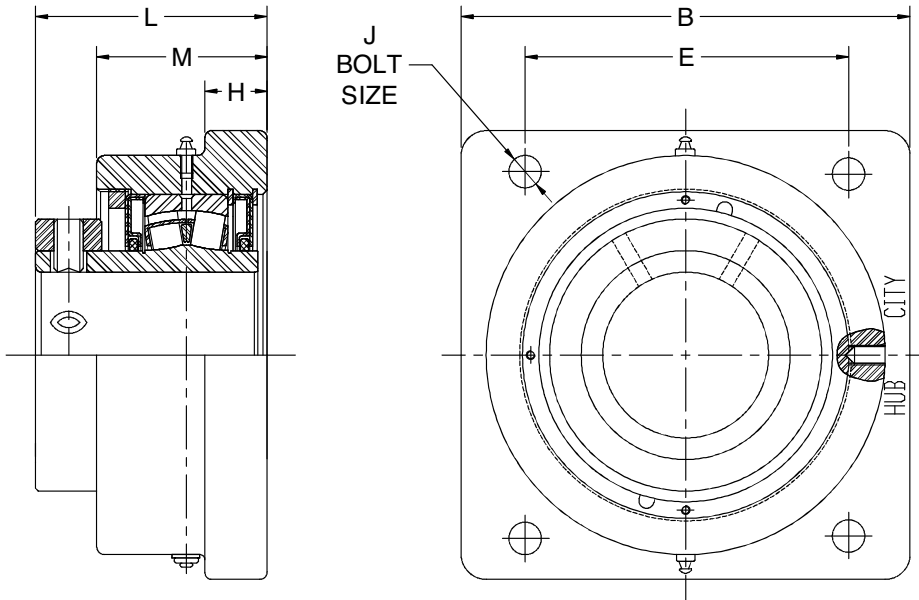

Note: Dimensions  $\frac{\text{in}}{\text{mm}}$   
Shown are:

### Four Bolt Flange Blocks

DESCRIPTION	BORE SIZE	SETSCREW	B	E	H	J (BOLT SIZE)	L	M	WEIGHT (LBS.)
KFBE1-7/16*	1.438	3/8-24 UNF	4.63	3.50	0.63	1/2	2.87	2.13	10
KFBE1-1/2*	1.500		[117.5]	[88.9]	[16.0]		[73.0]	[54.0]	
KFBE1-11/16*	1.688	3/8-24 UNF	5.38	4.13	0.63	1/2	2.99	2.20	10
KFBE1-3/4* Δ	1.750		[136.7]	[104.8]	[16.0]		[76.0]	[56.0]	
KFBE1-15/16*	1.938	3/8-24 UNF	5.62	4.38	0.63	1/2	2.99	2.20	12
KFBE2*	2.000		[142.7]	[111.1]	[16.0]		[76.0]	[56.0]	
KFBE2-3/16*	2.188	3/8-24 UNF	6.26	4.88	0.79	5/8	3.24	2.44	14
KFBE2-1/4* Δ	2.250		[159.0]	[123.8]	[20.0]		[82.4]	[62.0]	
KFBE2-7/16*	2.438	1/2-20 UNF	6.88	5.38	0.87	5/8	3.49	2.72	18
KFBE2-1/2*	2.500		[174.8]	[136.5]	[22.0]		[88.7]	[69.0]	
KFBE2-11/16*	2.688	1/2-20 UNF	7.76	6.00	0.87	3/4	3.74	2.72	24
KFBE2-3/4*	2.750								
KFBE2-15/16*	2.938								
KFBE3* Δ	3.000								
KFBE3-7/16*	3.438	1/2-20 UNF	9.25	7.00	0.94	3/4	4.15	3.11	35
KFBE3-1/2*	3.500								
KFBE3-15/16*	3.938	5/8-18 UNF	10.24	7.75	1.10	7.8	4.71	3.50	55
KFBE4*	4.000								

\* Specify Seal Design and Material  
 LT: Labyrinth Teflon (std)  
 DN: Double Lip Nitrile  
 TN: Triple Lip Nitrile  
 See pages P-3 and P-5 for more information

Δ Note: Confirm all critical mounting dimensions. Housing modifications may be required when interchanging with mounted tapered roller units.

# Hub City ModuLine® Spherical Roller Bearing Units

## Moduline® Accessories - Closed Covers

### Features

- Heavy duty metal construction
- Treated for corrosion resistance
- Can be filled with grease for an additional barrier of protection
- Includes mounting hardware for easy bolt-on attachment
- Designed for places where heavy contamination is a threat
- Effective in high moisture environments



### Closed Cover Dimensions

PART NUMBER	SHAFT SIZE (IN)	LENGTH FROM BEARING CENTERLINE	MAX SHAFT LENGTH (FROM CENTERLINE)	COVER BODY DIAMETER
1029-20401	1-7/16	2.8	2.5	2.75
	1-1/2			
1029-20402	1-11/16	2.8	2.5	2.95
	1-3/4			
1029-20403	1-15/16	2.9	2.7	3.15
	2			
1029-20404	2-3/16	3.2	2.9	3.55
	2-1/4			
1029-20405	2-7/16	3.7	3.4	4.20
	2-1/2			
1029-20406	2-11/16	3.7	3.4	4.60
	2-3/4			
	2-15/16			
	3			
1029-20407	3-7/16	4.2	3.9	5.50
	3-1/2			
1029-20408	3-15/16	4.5	4.2	6.32
	4			
1029-20409	4-7/16	5.3	5.0	7.10
1029-20410	4-15/16	5.3	5.0	8.25

DOWNLOAD AVAILABLE CAD MODELS AT: [WWW.HUBCITYINC.COM](http://WWW.HUBCITYINC.COM)

**Certified prints are available upon request**

CALL: (605) 225-0360 • FAX: (605) 225-0567



# Hub City ModuLine® Spherical Roller Bearing Units

## Moduline® Accessories - Open Covers



### Features

- Heavy duty metal construction
- Treated for corrosion resistance
- Can be filled with grease for an additional barrier of protection
- Includes mounting hardware for easy bolt-on attachment
- Designed for places where heavy contamination is a threat
- Effective in high moisture environments
- Equipped with Teflon Labyrinth seal for superior protection at all speeds and high temperatures

### Open Cover Dimensions

PART NUMBER	SHAFT SIZE (IN)	LENGTH FROM BEARING CENTERLINE	COVER BODY DIAMETER
1029-20411	1-7/16	2.3	2.75
1029-20412	1-1/2	2.3	2.75
1029-20413	1-11/16	2.5	2.95
1029-20414	1-3/4	2.5	2.95
1029-20415	1-15/16	2.5	3.15
1029-20416	2	2.5	3.15
1029-20417	2-3/16	2.5	3.55
1029-20418	2-1/4	2.5	3.55
1029-20419	2-7/16	2.7	4.20
1029-20420	2-1/2	2.7	4.20
1029-20421	2-11/16	3.0	4.60
1029-20422	2-3/4	3.0	4.60
1029-20423	2-15/16	3.0	4.60
1029-20424	3	3.0	4.60
1029-20425	3-7/16	3.3	5.50
1029-20426	3-1/2	3.3	5.50
1029-20427	3-15/16	3.5	6.32
1029-20428	4	3.5	6.32
1029-20429	4-7/16	4.3	7.10
1029-20430	4-15/16	4.3	8.25

# Hub City ModuLine® Spherical Roller Bearing Units

## Modified and Custom Designs

If you have looked through this catalog and do not see exactly what you need, Hub City has the capability and engineering expertise to design and produce modified or custom mounted bearings.

### Capabilities range as follows:

- Special sealing requirements or materials
- Special lubricants
- Housing modifications
- High temperature inserts and lubricants
- Special paint or housing coatings
- Modifications for specific or unique application requirements

Consult the factory or your Hub City representative with your specifications.